

User Manual

Ascom i75 VoWiFi Handset

Contents

1 Introduction	1
1.1 Abbreviations and Glossary	1
1.2 Versions	1
1.3 Functions	2
1.4 Accessories	2
2 Guideline for Safety and Efficiency for the i75 VoWiFi Handsets	3
2.1 Precautions	3
2.1.1 Potentially Explosive Atmospheres	3
2.2 Frequency	4
2.2.1 Frequency Range	4
2.2.2 Exposure to Radio Frequency Signals	4
2.3 FCC Compliance Statements	5
2.3.1 Operation Procedures by FCC	5
2.4 IC Requirements for Canada	5
2.5 Battery Care	6
2.5.1 Battery Disposal	6
2.6 Chemical Resistance	6
2.7 Warranty Notification	6
2.8 Modifications	6
3 Description of the Handset	7
3.1 Handset Overview	7
3.2 Keys and Buttons	8
3.2.1 Navigation key	8
3.2.2 Off-hook Key	8
3.2.3 Volume Button	9
3.2.4 Alarm Button	9
3.2.5 Mute Button	9
3.2.6 Soft Keys	9
3.2.7 On/Off and On-hook Key	10
3.2.8 Alpha Numeric Keys	10
3.2.9 Hot Keys	11
3.3 Icons and Text in the Display	11
3.4 Handset Memory	13
4 Accessories	14
4.1 Belt Clip, Swivel-type	14
4.2 Leather Casing	14
4.3 Headset	14
4.4 Security String	14

4.5 USB Programming Device	14
5 Chargers.....	15
5.1 Desktop Charger	15
5.2 Wall Mounted Charging Racks	15
6 Navigate the Menu	16
6.1 Enter/Exit the Menu Mode	16
7 Menu Tree Structure	17
7.1 Contacts	17
7.2 Messages	17
7.3 Call List	17
7.4 Services	17
7.5 Settings	18
7.6 Profiles	19
7.7 Customize the Menu Tree	19
7.8 In Call Menu	20
8 Basic Operation	21
8.1 Switch the Handset On/Off	21
8.2 Log a Shared Phone On/Off	21
8.3 Turn Audible Signals On/Off	21
8.4 Lock/Unlock the Keypad	21
8.5 Lock/Unlock the Handset	22
9 Calling	23
9.1 Open the Call List	23
9.2 Incoming Call	23
9.2.1 Turn Off Alert Signals at an Incoming Call	23
9.2.2 End a Call	23
9.3 Outgoing Call	23
9.3.1 Pre-dial	23
9.3.2 Post-dial	24
9.3.3 Dial Using a Pre-programmed Hot key or Soft key	24
9.3.4 Dial a Number from the Call list	24
9.3.5 Dial a Number from a Message	24
9.3.6 Dial a Number from the Local Phonebook	24
9.3.7 Dial a Number from the Central Phonebook	24
9.4 During a Call	24
9.4.1 Start a New Call during Conversation	24
9.4.2 Transfer/Retrieve a Call	24
9.4.3 "Blind" Transfer	24
9.4.4 Put a Call on Hold/Retrieve the Call	25

9.4.5 Turn the Mute Mode On/Off	25
9.4.6 Increase/Decrease the Speaker Volume	25
9.5 Loudspeaking Function	25
10 Call Diversion.....	26
10.1 Preset the Telephone Numbers	26
10.2 Divert Calls	26
11 Push-to-Talk Conference Call.....	27
11.1 Send an Invitation to a PTT Group	27
11.2 Accept a PTT Conference Call	27
11.3 Reject a PTT Conference Call	27
12 Messaging.....	28
12.1 Message List	28
12.1.1 Display and Scroll between Messages	28
12.1.2 Read Stored Messages	29
12.1.3 Message Queuing and Message Priority	30
12.2 Basic Message Handling	32
12.2.1 Receive a Message	32
12.2.2 Receive a Message during a Call	32
12.2.3 Receive a Message with Request for Answer	32
12.2.4 Delete a Message	32
12.3 Messaging between Handsets	33
12.3.1 Send a Message to another Handset	33
12.4 Send a Message to a predefined Destination Address	33
12.5 Interactive Messaging	33
12.5.1 Interactive Messages with Function Keys	34
12.5.2 Interactive Messages without Function Keys	34
12.5.3 Multilayer Interactive Messaging	34
12.6 Voice Mail	34
12.6.1 Receive a Voice Mail	34
12.7 Send Data from the Handset	34
12.7.1 Data Send	34
12.7.2 Send Data with a Prefix	34
13 Presence Management	35
13.1 Select Presence Activity	35
14 Alarm Operation	36
14.1 Acoustic Localisation Signal	36
14.2 Push-button Alarm	36
14.3 Test Alarm	36
14.4 No-movement Alarm	36

14.5 Man-down Alarm	37
14.5.1 Delay Time for No-movement and Man-down Alarms Warning Signal	37
14.6 Alarm with Data	37
14.7 Automatic Call after an Alarm	37
14.8 Automatic Alarm after Emergency Call	38
15 Menu Operation.....	39
15.1 Contacts	39
15.1.1 Find an Entry in the Local Phonebook	39
15.1.2 View an Entry in the Local Phonebook	39
15.1.3 Add an Entry to the Local Phonebook	39
15.1.4 Delete an Entry in the Local Phonebook	40
15.1.5 Edit an Entry in the Local Phonebook	40
15.1.6 Find an Entry in the Central Phonebook	41
15.1.7 Delete the Central Phonebook Search Result	41
15.1.8 Add an Entry from the Search Result to the Local Phonebook	41
15.1.9 Send a Message to an Entry in Contacts	41
15.2 Messages	41
15.2.1 Message List	42
15.3 Call List	43
15.3.1 Save a Number from the Call List to the Local Phonebook	43
15.3.2 Delete a Number in the Call List	43
15.3.3 Delete All Numbers in the Call List	43
15.4 Services	43
15.4.1 Activate a Service	44
15.4.2 Create a new Service	44
15.4.3 Edit a Service	44
15.4.4 Delete a Service	45
15.5 Settings	45
15.5.1 Change the Ring Volume	45
15.5.2 Change the Ring Signal	46
15.5.3 Change the Speaker, Loudspeaker or Headset Volume	46
15.5.4 Vibrator On/Off	46
15.5.5 Key Beep On/Off	46
15.5.6 Deactivate/Activate No-movement alarm	46
15.5.7 Deactivate/Activate Man-down alarm ¹	46
15.5.8 Edit a Soft key	47
15.5.9 Edit a Hot key	48
15.5.10 Select Language	48
15.5.11 Change Text Size in Messages	49
15.5.12 Lock the Handset Manually	49

15.5.13 Change the Lock Code ¹	49
15.5.14 Time and Date Settings	49
15.5.15 Turn On/Off Automatic Keypad Lock	49
15.5.16 Enable/Disable Quick Answer	50
15.5.17 Display New Messages 180° Rotated (upside down)	50
15.5.18 Set Owner ID	50
15.5.19 Change Display Contrast	50
15.5.20 Select System	50
15.5.21 System Information	51
15.6 Profiles	51
15.6.1 Change between the Profiles	52
15.6.2 Change Profile Settings	52
15.6.3 Set the Profile to Absent On/Off	52
15.6.4 Choose the Profile's Answering method	52
15.6.5 Set the Profile to Divert incoming Calls	52
15.6.6 Preset Phone Numbers for the Diversions alternatives	53
15.6.7 Customizing the Profiles Menu	53
16 System Handling	54
16.1 Register a New VoWiFi System	54
16.2 Field Upgrade	54
17 Status text in Display	55
17.1 Accessibility and Voice Quality	55
17.2 Error Codes	55
17.3 Environmental Requirements	56
18 Maintenance	57
18.1 Charge the Battery	57
18.1.1 Charging Spare Batteries	57
18.2 Remove the Battery	57
18.3 Change the Clip	58
19 Related Documents	59
Document History	60
Index	61

1 Introduction

The Ascom i75 VoWiFi Handset is part of the Ascom VoWiFi system. With the i75 VoWiFi handset you can maintain connectivity to traditional telephone services while remaining mobile around the work environment.

This document describes the features and settings available for the i75 VoWiFi Handset. All procedures in this document are according to default programmed versions, but additional functions and factory settings are also included as an attempt to cover all functionality.

Note: 1) Some functions are PBX and protocol (H.323/SIP) dependent and your system may not supply all functions described in this document. For more information about your system please contact the person (or department) responsible for the system in your organization, or contact your supplier.

2) This document includes important safety information and operating instructions, see chapter [2 *Guideline for Safety and Efficiency for the i75 VoWiFi Handsets*](#) on page 3. Please read this information before using your i75 VoWiFi handset and save this manual with all instructions for future reference.

1.1 Abbreviations and Glossary

ESSID	Extended Service Set Identifier: Identifier for the mobile devices attempting to connect to the VoWiFi system.
IMS/IP	Integrated Message Server for the VoWiFi system.
IP	Internet Protocol: Global standard that specifies the format of datagrams and the addressing scheme.
PDM	Portable Device Manager: Used for management of portables, editing of parameters and updating the portables with new software.
VoIP	Voice over Internet Protocol
VoWiFi	Voice over Wireless Fidelity: Is a wireless version of VoIP and reeferes to IEEE 802.11a, 802.11b or 802.11g network.
WiFi	Wireless Fidelity: Is used generically when referring of any type of 802.11 network.

1.2 Versions

The Ascom i75 VoWiFi Handset is a robust handset designed for people working in tough environments. It is suitable for users dependent of being reachable and/or having a need for advanced mobile messaging functions. The handset comes in two versions, i75 Protector and i75 Medic Protector.

1.3 Functions

- Local phonebook
- Central phonebook
- Vibrator
- Microphone on/off during call
- Headset connector
- Presence*
- Push-To-Talk (PTT)*
- Messaging*
- Acknowledge*
- Interactive messaging*
- Data send*
- Data with prefix*
- Alarm with data*
- Location*
- Man-down & No-movement alarm*

* *System dependent feature*

1.4 Accessories

- Headset
 - with mic (2 types)
 - with hearing protection
- Belt clip
 - hinge-type
 - swivel-type
- Leather casing
- Security string
- Desktop charger
- Charging rack
- Battery pack charger (each module supports eight batteries)
- Spare battery
- USB programming device

2 Guideline for Safety and Efficiency for the i75 VoWiFi Handsets

For safe and efficient operation of the VoWiFi handset, please read and observe the guidelines given in this chapter and all necessary safety precautions when using the handset. Follow the operating instructions and adhere to all warnings and safety precautions located on the product, the Quick Reference Guide and this User Manual.

2.1 Precautions

- Connect AC (power supply) to the desktop battery charger only to designated power sources as marked on the product.
Danger: Never alter the AC cord or plug. If the plug will not fit into the outlet, have a proper outlet installed by a qualified electrician. Improper connection increases the risk of electric shock.
- Position the electrical cord to the AC power supply where it is least likely to be subjected to damage or stress.
- Remove the electrical cord from an outlet by pulling gently on the AC adapter, not by pulling the cord.
- Remove the battery before cleaning the telephone to reduce risk of electric shock.
- Do not use auxiliary equipment with the VoWiFi handset which is not exclusively recommended by the manufacturer, see [1.4 Accessories](#) on page 2. The use of any auxiliary equipment not recommended by the manufacturer may result in fire, electric shock, or injury, and will void the warranty.
- Do not expose the VoWiFi handset to open flame.
- Do not expose the VoWiFi handset and the charger to direct sunlight for long periods. Keep the handset and charger away from excessive heat and moisture.
- Do not allow heavy objects to fall on the VoWiFi handset.
- Do not allow children to play with the product packaging material. Product packaging material is often small and may present a choking hazard.
- Do not allow children to play with your handset. It is not a toy. Children could hurt themselves or others. Children could also damage the handset.
- The user must be aware that privacy of communications may not be ensured when using this VoWiFi handset.

2.1.1 Potentially Explosive Atmospheres

Turn the VoWiFi handset off when in an area with a potentially explosive atmosphere. It is rare, but the telephone or its accessories could generate sparks. Sparks in such areas could cause an explosion or fire resulting in bodily injury or even death.

Areas with a potentially explosive atmosphere are often, but not always, clearly marked. They include fuelling areas, (such as gas stations), below deck on boats, fuel or chemical transfer or storage facilities, and areas where the air contains chemicals or particles (such as grain, dust, or metal powders).

Do not transport or store flammable gas, liquid, or explosives in any compartment of a vehicle which also contains the telephone and accessories.

In the U.S., vehicles powered by liquid petroleum gas (such as propane or butane) must comply with the National Fire Protection Standard (NFPA-58). For a copy of this standard, contact the National Fire Protection Association, One Battery march Park, Quince, Massachusetts 02269, Attention: Publication Sales Division.

2.2 Frequency

2.2.1 Frequency Range

Your i75 VoWiFi handset is a radio transmitter and receiver. When it is on, it receives and sends out radio frequency (RF) energy. The handset operates in the frequency range of 2412 – 2462 MHz for Canada and USA and 2412 – 2472 MHz for Europe and employs commonly used modulation techniques.

2.2.2 Exposure to Radio Frequency Signals

The VoWiFi handset is a radio transmitter and receiver. It is designed and manufactured not to exceed the emission limit for exposure to radio frequency (RF) energy set by the Federal Communications Commission (FCC) of the U.S. Government and Canada. These limits are part of comprehensive guidelines and established permitted levels of RF energy for the general population. These guidelines are based on the safety standards previously set by both U.S. and international standards bodies.

These standards include a substantial safety margin designed to assure the safety of all persons, regardless of age and health. The exposure standards for wireless mobile telephones employs a unit of measure known as the **SAR** (Specific Absorption Rate).

Tests for SAR are conducted using standard operating positions specified by the FCC with the telephone transmitting at its highest certified power level in all tested frequency bands. Although the SAR is determined at the highest certified power level, the actual SAR level of the telephone while operating can be well below the maximum value. This is because the telephone is designed to operate at multiple power levels. The SAR limit set by the FCC and Canada is 1.6W/kg averaged over one gram of tissue.

Before a telephone model is available for sale to the public, it must be tested and certified to the FCC that it does not exceed the limit established by government-adopted requirement for safe exposure. The tests are performed in positions and locations (for example, at the ear and worn on the body) as required by the FCC for each model.

The highest SAR value for this telephone when tested for normal operation is 0.036 W/kg. While there may be differences between the SAR levels of various telephones and at various positions, they all meet the government requirement for safe exposure.
--

The highest SAR value for this telephone when tested for body worn operation is 0.117 W/kg. While there may be differences between the SAR levels of various telephones and at various positions, they all meet the government requirement for safe exposure.

For body worn operation, to maintain compliance with FCC RF exposure guidelines, use only accessories approved by your supplier. When carrying the handset while it is on, use only the specific belt clip that has been tested for compliance.

Use of non-Ascom approved accessories may violate the FCC RF exposure guidelines and should be avoided.

Most modern electronic equipment (for example, equipment in hospitals and cars) is shielded from RF energy. However, RF energy from VoWiFi handsets may affect some electronic equipment.

RF Exposure: This device and its antenna must not be co-located or operating in conjunction with any other antenna or transmitter.

This device has been shown to be capable of compliance for localized specific absorption rate (SAR) for uncontrolled environment/general population exposure limits specified in ANSI/IEEE Std. C95.1-1992 and had been tested in accordance with the measurement

procedures specified in FCC/OET Bulletin 65 Supplement C (2001) and IEEE Std. 1528-2003 December 2003).

The FCC has granted an equipment authorization for the i75 VoWiFi handset with all reported SAR levels evaluated as in compliance with the FCC RF emissions guidelines. SAR information for the i75 VoWiFi handset is on file at FCC and can be found under the Display Grant section of <https://gulfoss2.fcc.gov/prod/oet/cf/eas/reports/GenericSearch.cfm> after searching on FCC ID BXZKATY.

2.3 FCC Compliance Statements

This device complies with Part 15 of the FCC Rules. Operation is subject to the following two conditions: (1) this device may not cause harmful interference, and (2) this device must accept any interference received, including interference that may cause undesired operation.

Note: This equipment has been tested and found to comply with the limits for a Class B digital device, pursuant to Part 15 of the FCC Rules. These limits are designed to provide reasonable protection against harmful interference in a residential installation. This equipment generates, uses and can radiate radio frequency energy and, if not installed and used in accordance with the instructions, may cause harmful interference to radio communications.

However, there is no guarantee that interference will not occur in a particular installation. If this equipment does cause harmful interference to radio or television reception, which can be determined by turning the equipment off and on, the user is encouraged to try to correct the interference by one or more of the following measures:

- Reorient or relocate the receiving antenna.
- Increase the separation between the equipment and receiver.
- Connect the equipment into an outlet on a circuit different from that to which the receiver is connected.
- Consult the dealer or an experienced radio/TV technician for help.

2.3.1 Operation Procedures by FCC

In the U.S, cordless telephones are subject to the rules and regulations of the FCC. Following these rules will help to eliminate confusion, ensure the most efficient use of the existing frequencies, and result in a smoothly functioning radio network.

The following offences are punishable by fine, imprisonment, or both:

- Use of profane, indecent, or obscene language.
- Transmission of a false distress signaller call.
- Wilful or malicious interference with any other radio communications.
- Refusal to yield a channel or radio frequency when informed that it is needed for an emergency call. Emergency calls have priority over all messages.
- Adjustment of the equipment by anyone other than a qualified licensed technician.

2.4 IC Requirements for Canada

The i75 VoWiFi handset is marked with **IC:3724B-KATY**. The term "IC:" before the radio certification number signifies that Industry of Canada technical specifications were met.

2.5 Battery Care

- Do not leave a battery where it could be subjected to extremely high temperatures, such as inside a car on a hot day.
- Do not allow the metal contacts on the battery to touch another metal object. This could short-circuit and damage the battery.
- Do not attempt to take a battery apart.
- Do not expose a battery to an open flame. This could cause the battery to explode.
- Do not charge a battery when the ambient room temperature is above 104°F or 40°C or below 41°F or 5°C.
- Do power the i75 VoWiFi handset off before removing the battery.

2.5.1 Battery Disposal

Defective batteries must be returned to a collection point for chemical waste disposal.

2.6 Chemical Resistance

The alpha and numeric characters printed on the exterior of the VoWiFi handset have been tested and found resistant to chipping, fading or wearing off when the telephone is treated with common cleaners and disinfectants or perspiration. The following chemicals have shown no harmful effect:

- 3% Hydrochloric Acid
- M-alcohol (70% Methylated Ethanol)
- 60% Chlorhexidin 0.5mg/ml

Acetone can be damaging to the plastic casing of the VoWiFi handset and should not be used.

2.7 Warranty Notification

Do not disassemble the VoWiFi handset. Disassembling the handset voids the warranty. The i75 VoWiFi handset consists of no consumer serviceable components. Service should be performed only by Authorized Service center.

2.8 Modifications

Modifications not expressly approved by the supplier could void the user's authority to operate the equipment.

3 Description of the Handset

3.1 Handset Overview

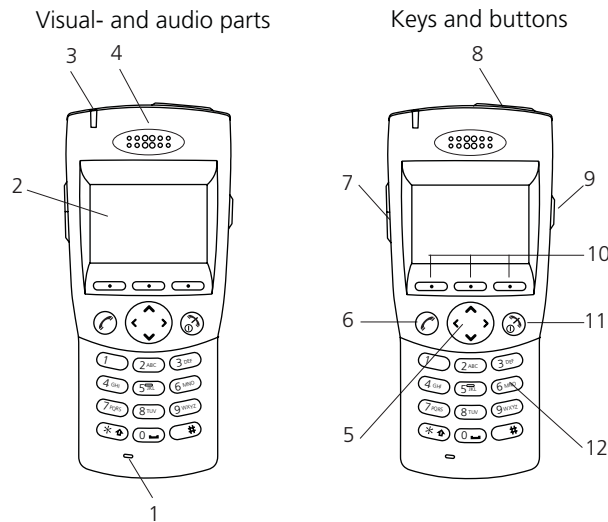

001

Figure 1. The i75 VoWiFi handset

- 1 Microphone
- 2 Display
- 3 LED
- 4 Loudspeaker
- 5 Navigation key
- 6 Off-hook Key
- 7 Volume Button
- 8 Alarm Button
- 9 Mute Button
- 10 Soft Keys
- 11 On/Off and On-hook Key
- 12 Alpha Numeric Keys

Case

The case is made of durable PC/ABS plastic.

The i75 Handset has the enclosure protection IP40 and it also fulfils IEC 68-2-32 procedure 1, which makes it drop proof from 1.5 meters onto concrete.

Antenna

The antenna is integrated inside the handset.

Display

The display is an illuminated 128 x 64 pixels LCD, covered by anti-reflex treated plastic glass for maximum readability.

Keypad

The keypad is illuminated, which makes it possible to operate the handset in dark environments. While not in use, the keypad should be locked to prevent pressing a key accidentally.

Clip, Hinge-type

The clip on the back of the handset helps you fasten the handset to a belt or similar. It is also possible to change the clip to a swivel-type or, if no clip is needed, to replace it with a covering plate.

Battery





The battery is a rechargeable Li-Ion battery placed on the back of the handset.

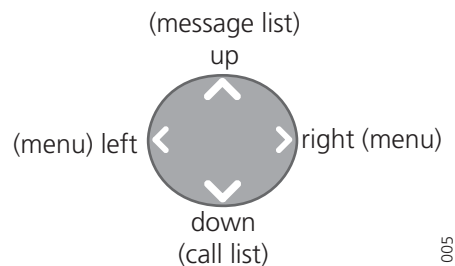

3.2 Keys and Buttons

3.2.1 Navigation key



The Navigation key controls the movement of the cursor in the display.

In stand-by mode the Navigation key  is used for entering the Call list, the Navigation key  for entering the Message list, and the Navigation key   for entering the menu.

In menu mode, the Navigation key (all directions) is used for scrolling, in the submenus the Navigation key   is used for scrolling through the entries.

Note: These are the default settings for the Navigation key. They can be changed using the Portable Device Manager.

3.2.2 Off-hook Key



The Off-hook key is used for connecting calls.

3.2.3 Volume Button

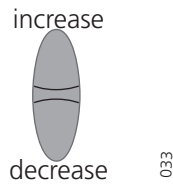

The Volume button is used for increasing/decreasing the volume. The adjusted volume is saved in the handset.

3.2.4 Alarm Button

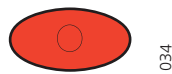

The red Alarm button is used for sending alarms and testing the alarm function (test alarm). If programmed the handset can automatically dial a predefined telephone number directly after an alarm is sent.

3.2.5 Mute Button



The Mute button is used for silencing the audible signals in stand-by mode, silencing the ring signal at an incoming call, and also to turn off/on the microphone during a call.

3.2.6 Soft Keys

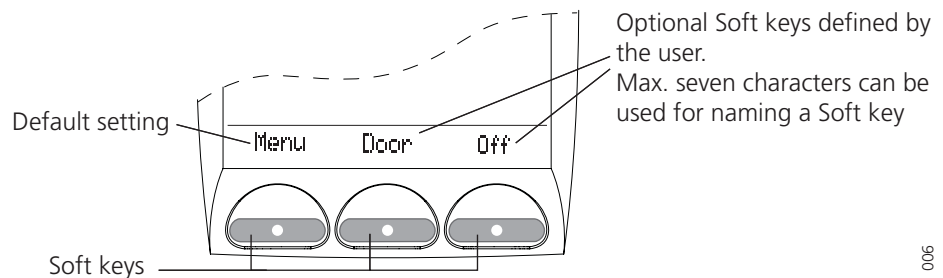

Figure 2. Navigation key functions in stand-by mode (default).

The three Soft keys are located just beneath the display and the function of each Soft key is indicated by text in the display just above the keys.

In stand-by mode the Soft keys can be used for specific functions defined by the user of the handset. The function can be to dial a specific telephone number, sending data, a short-cut to the *Menu*, or sending a message.

When navigating in menu mode the Soft keys are used for menu choices.

Note: The Soft key *Menu* is a default setting but all Soft key settings can be changed by the user or the system administrator.

3.2.7 On/Off and On-hook Key



The On/off and On-hook key is used for disconnecting calls and for switching the handset on and off.

3.2.8 Alpha Numeric Keys

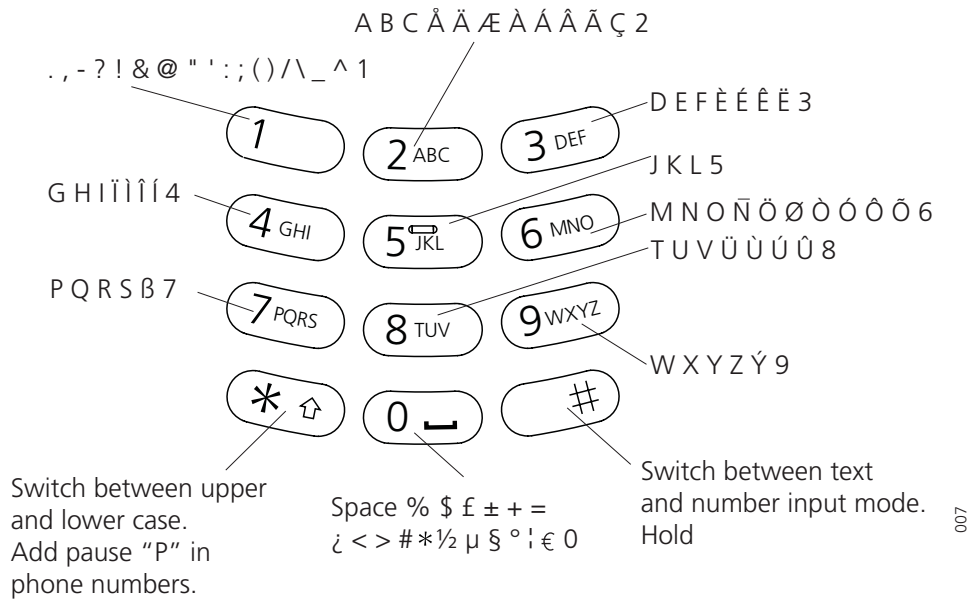

In some applications you have the possibility to write letters as well as numbers, which is indicated by the *ABC* icon. Pressing the numerical keys will now give you access to the alphabet plus some special characters according to the picture.

In Stand-by Mode

In stand-by mode short presses on the keys enter the digits, and the characters * and #. A long press on a key "0" - "9" activates the programmed Hot key function.

In Text Input Mode

In text input mode a press on a key displays the first available character on that specific key. Press the key repeatedly to view the characters following the first. The marked character is selected after a time out or when another key is pressed. Press the *-key to switch between upper case and lower case. Press and hold a key to enter a number in text input mode, or press repeatedly until the number is shown.

Press and hold the #-key in order to switch between text and number input mode.

In Dialling mode

If a pause is required in a phone number, it is added by making a long press on the *-key. The pause is indicated with a "P" in the number.

3.2.9 Hot Keys

Any key “0”–“9” can be set to a Hot key. A Hot key can be programmed to give access to frequently used functions such as dialling a specific handset number, sending data, a short-cut to the menu, or sending a message. Note that the possibility to define a Hot key can be locked by the system administrator.

3.3 Icons and Text in the Display

The icons and text in the display indicate functions and settings to which you have access. The display normally shows date and time, the owner ID and telephone number. The owner ID can manually be set by the user.

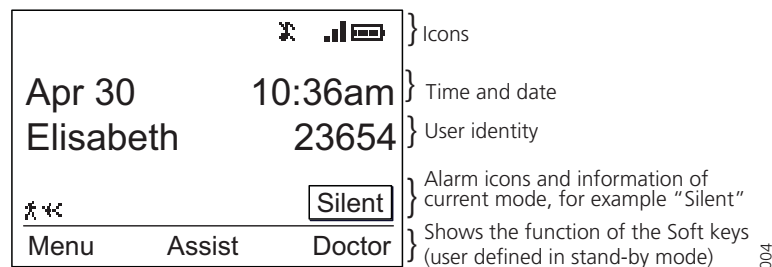

Figure 3. Example of a display configuration in stand-by mode.

In stand-by mode the upper row is used for icons. Three rows are used for information. The first row shows the date and time and the second row is used for user information. The user information in stand-by mode can be set by the user. The third information row is used for showing the alarm icons and status of the handset. Examples of status information are; muted, in charger etc. When there is no status to show the row is empty.

The bottom row (under the line) is the Soft key field. In stand-by mode it shows the user defined names of the three Soft keys beneath the display. In menu mode where the Soft keys are used for different choices, it gives you the function of each Soft key. Examples of functions are; Select, Back, Option, Save etc.



The “Off-hook” icon indicates that your handset is off-hook.



The “Audio signals” off icon is shown when all alert signals, including ring signal, message tone, key beep etc. are turned off. High priority messages will however override this setting.



The “Signal strength” icon is always shown in the display in stand-by mode. The level indicators decreases when the signal strength becomes weaker.



The “Battery” icon is always shown in the display in stand-by mode. When the level is low it is time to charge the battery.



The “Loudspeaking on” icon is shown when it is possible to use the loudspeaking function.



The “Loudspeaking off” icon is shown when the loudspeaker is activated.



The “New voice mail” icon appears when a new voice mail exists. The symbol will remain until all voice mails has been listened to and/or removed. (Note: This is dependent on voice mail system.)



The “Key lock” icon indicates when your keypad is locked.



The “Padlock” icon indicates that the IP handset has been locked, and has to be unlocked with a code before it can be used.



The “Headset” icon indicates that a headset is connected to the handset.



The “No-movement” alarm *on* icon indicates that the no-movement alarm is activated.



The “Man-down alarm on” icon indicates that the man-down alarm is activated.



“ABC” indicates that you can type upper case letters and numbers in text input mode.



“abc” indicates that you can type lower case letters and numbers in text input mode.



“123” indicates that you can type numbers in text input mode.



The “Incoming call” icon is added in front of incoming calls in the call list.



The “Outgoing call” icon is added in front of outgoing calls in the call list.



The “Missed call” icon is added in front of unanswered calls in the call list



The “Diverted” icon is added in front of the number that the calls are diverted to.



The “Unread message” icon is added in front of not read messages in the message list.



The “Read message” icon is added in front of read messages in the message list.



A “Message continue” icon is shown when the message text continues above or below the current screen.



The “Interactive message” icon is added in front of not read interactive messages in the message list.



The “Read interactive message” icon is added in front of read interactive messages in the message list.



The “Action required” icon is added in front of messages where an action is required.



The “New message” icon appears when a new message is received. The number on the right side of the icon shows the total number of unread messages. The symbol will remain until the message is marked as read.



The “Add contact” icon appears on a Soft key when a phone number is marked in the call list. It indicates that it is possible to add the phone number to the local phonebook.



The “Get contact from phonebook” icon is visible when it is possible to get a phone number from the local phonebook, for example to add it to a function.

Menu Icons: Icons displayed in Menu mode



Under the icon “Contacts” in the menu mode, you can find the local and central phone books. See [15.1 Contacts](#) on page 39.



Under the icon “Messages” in the menu mode, you can find the message list and the menu entry for sending messages. See [15.2 Messages](#) on page 41.



Under the icon “Call list” in the menu mode, you can find the call list. See [15.3 Call List](#) on page 43.



Under the icon “Services” in the menu mode, you can select, add, delete, or change a service function. See [15.4 Services](#) on page 43.



Under the icon “Settings” in the menu mode, you do your handset settings. See [15.5 Settings](#) on page 45.



Under the icon “Profiles” in the menu mode, you can select a profile and edit profiles. See [15.6 Profiles](#) on page 51.

3.4 Handset Memory

The handset memory contains all personal settings such as phonebook, identity, alert signal and your defined functions of the Soft keys and Hot keys. All personal settings are downloaded to the memory when the user logs into the WLAN network. In addition, the memory holds up to two versions of the firmware.

4 Accessories

4.1 Belt Clip, Swivel-type

The ordinary belt clip can be replaced with a special swivel-type belt clip adapted to firmly place your handset onto your belt.

4.2 Leather Casing

The leather casing is especially designed for the handset. The casing comes with a swivel-type belt clip and the handset is fully operational while placed in the casing.

4.3 Headset

A headset is recommended if you frequently use the phone, and/or want to have both hands free. The handset has a special headset connector that is waterproof. The headset comes in three versions; with microphone integrated in the cable, with microphone on a boom, and with hearing protection (Peltor). An adapter, that makes it possible to connect other standard types of Peltor headsets, is also available.

4.4 Security String

The security string is 800 mm long. Fasten one end to the hinge-type belt clip and the other end to, for example, your pocket.

4.5 USB Programming Device

Similar to the Desktop charger in design, the USB programming device is used to connect your handset to a computer in order to upgrade the firmware and edit parameters.

5 Chargers

5.1 Desktop Charger

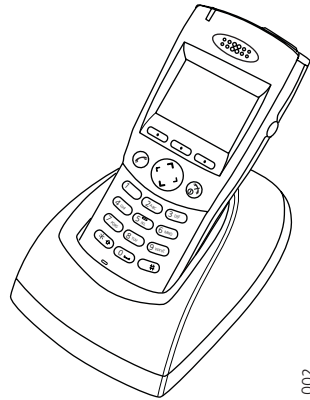

Figure 4. i75 in Desktop Charger.

The Desktop Charger is used for charging your handset, for example at your desk. The tilted design facilitates the use of handsfree operation, for example in loudspeaking mode. The charger is delivered with a plug-in power supply and is connected into a wall socket.

5.2 Wall Mounted Charging Racks

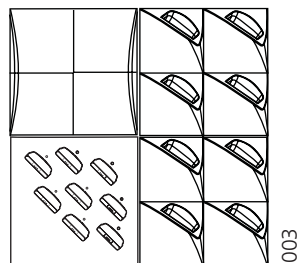

Figure 5. Example; two charging racks for handsets and one for spare batteries.

Wall mounted charging racks is used for charging handsets and spare batteries. The charging racks and its power supply are a modular system which enables a number of installation configurations. Each power supply can support three charging racks with four positions for handsets, or eight positions for batteries, in each rack (see the Data Sheet for Charging Rack).

As the handset cannot distinguish between a Desktop Charger and Charging Rack, it is recommended that the alert signal is silenced when placed in a rack. It can be set in the "In charger" profile, see [15.6.2 Change Profile Settings](#) on page 52.

6 Navigate the Menu

The choices in the main menu are displayed graphically with symbols, while the alternatives in the submenus are displayed as a list.

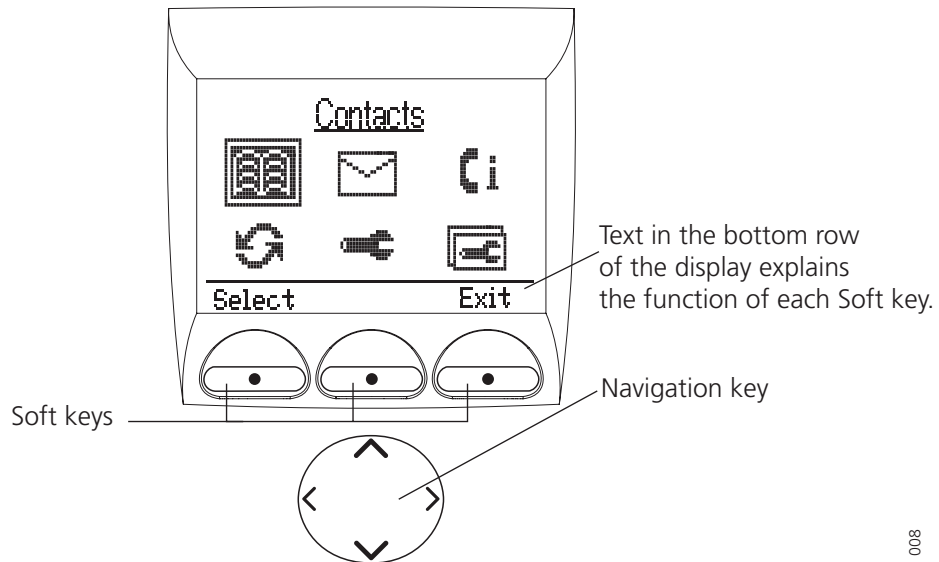

Figure 6. The main menu and the keys used for navigating.

6.1 Enter/Exit the Menu Mode

The three Soft keys located just beneath the display are used for choices in the menu. The bottom row in the display is the Soft key field and the text gives you the function of each Soft key. Examples of functions are; Select, Back, Exit, Cancel, Save, Delete, Options, Yes, No etc.

- 1 Enter the menu by pressing the "Menu" Soft key, or the Navigation key < or >.
- 2 Use the Navigation key to choose icon and press "Select" to open its corresponding submenu; a heading is shown and the first alternative is marked.
Use ^ v to step through the alternatives, and select an alternative by pressing "Select".

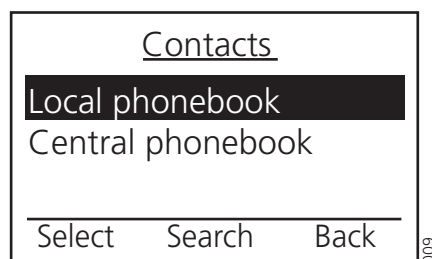



Figure 7. The Contacts submenu.

When you are in the Menu mode and have entered a submenu, a press on "Back" takes you back one step.

- 3 Return to stand-by mode by pressing and holding the "Back" Soft key or by a press on the  button. You can also step back to stand-by mode by short presses on the "Back/Exit" Soft key.

7 Menu Tree Structure

7.1 Contacts

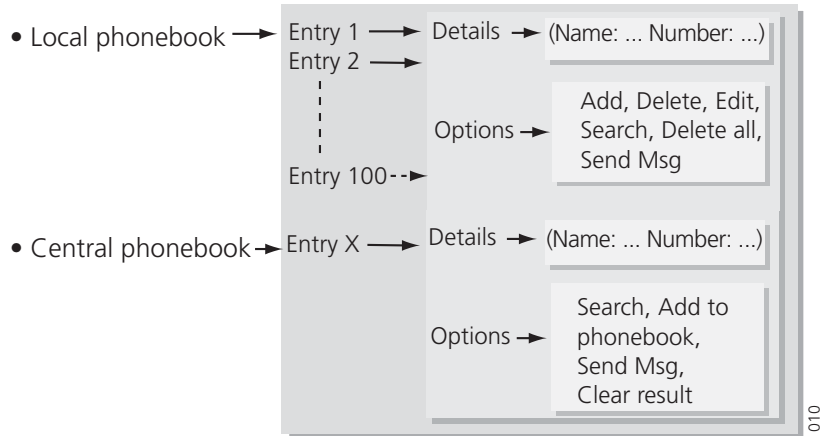

7.2 Messages

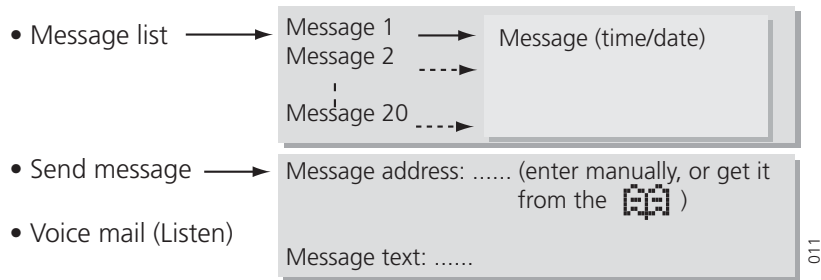

7.3 Call List

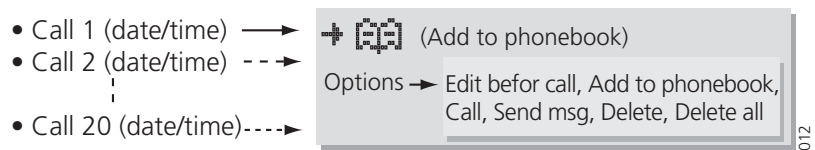

7.4 Services

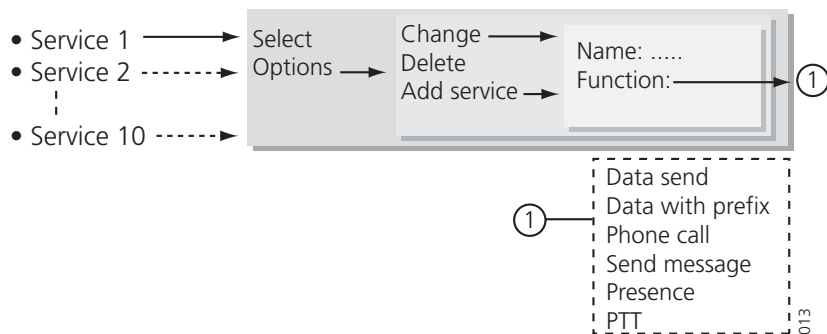

7.5 Settings

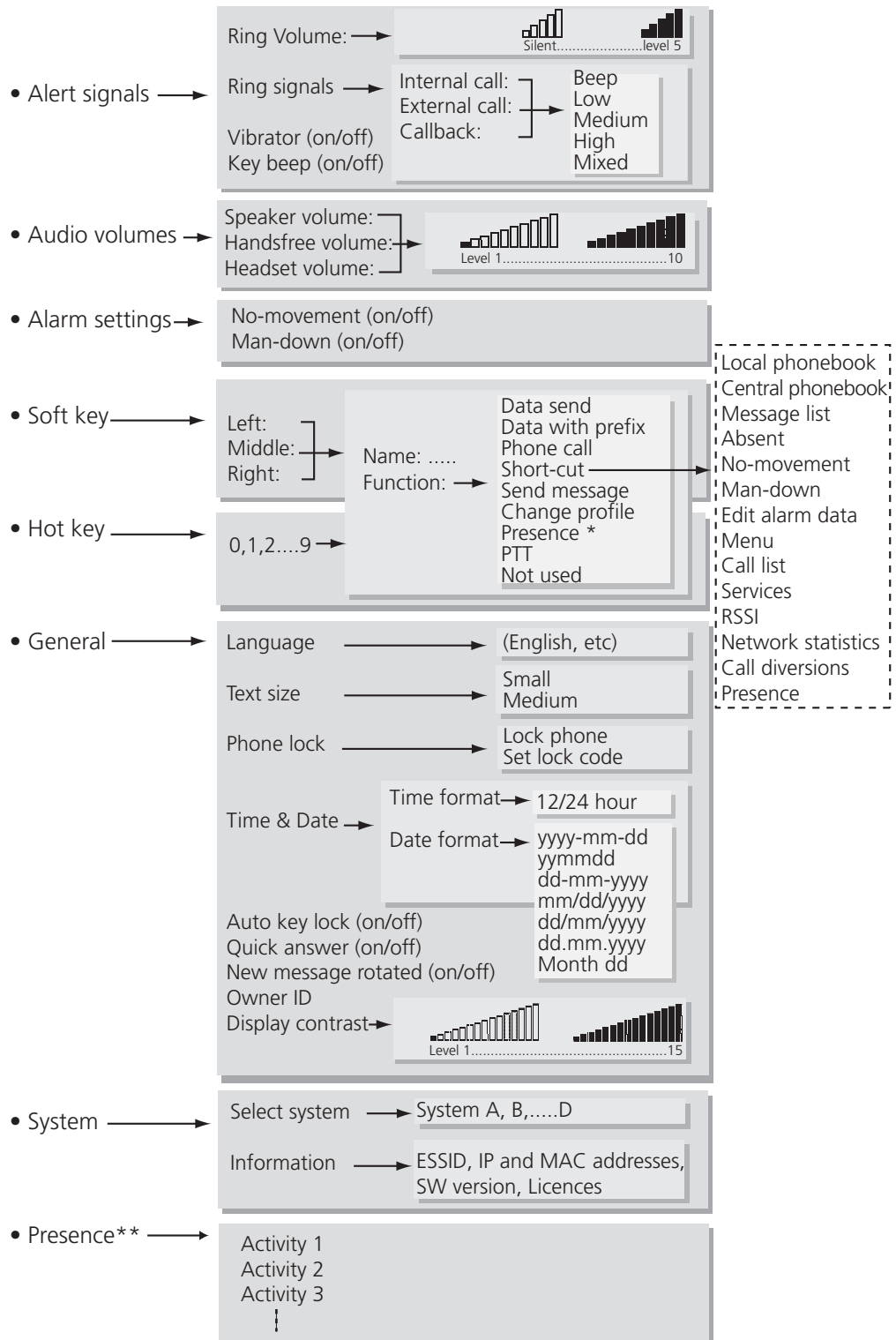

* An activity list is only visible if a Presence Management system is connected to the VoWiFi System

** The option is only visible if a Presence Management system is connected to the VoWiFi System

7.6 Profiles

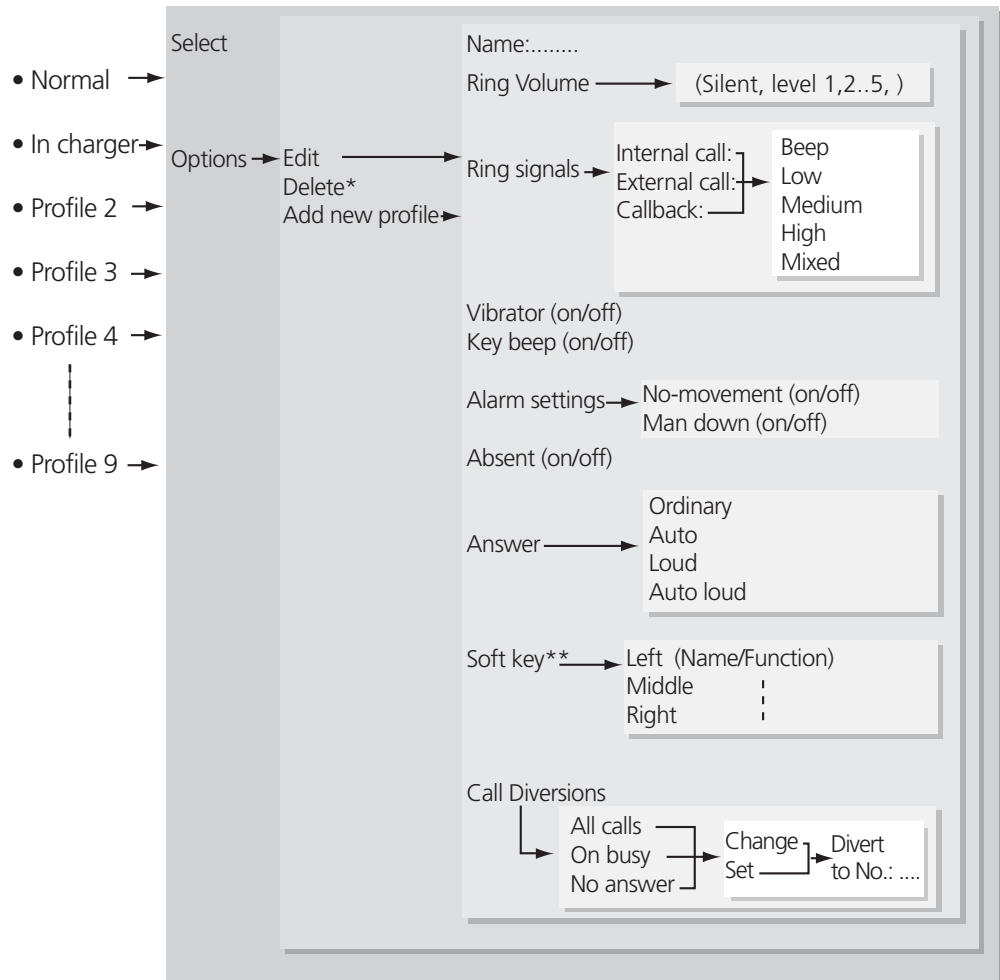

* Not applicable for the "Normal" and "In charger" profiles

** See Soft key settings in the "Settings" submenu

015

7.7 Customize the Menu Tree

The menu tree can be customized by hiding some of the available functions. Which functions that should be hidden are determined by settings in the handset memory. The following functions can be hidden.

Function	Description
Deletion of messages:	The options delete and delete all are hidden.
Administration of Local phonebook:	It is not possible to add new entries, or edit and delete existing entries.
Editing profiles:	The settings for the profiles cannot be altered.
Changing profiles:	The option select is hidden, i.e. it is not possible to change profiles from the menu.
Administration of Services:	It is not possible to add new services, or edit and delete existing services.
Changing Alert Signals:	The Alert Signals alternative in the menu is hidden.
Changing Alarm Settings:	The Alarm Settings alternative in the menu is hidden.

Administration of Soft keys:	The Soft key alternative in the menu is hidden.
Administration of Hot keys:	The Hot key alternative in the menu is hidden.
Editing Hot keys:	The option edit is hidden. It is possible to see the settings for the Hot keys.
Changing General Settings:	The General Settings alternative in the menu is hidden.
Handling Phone Lock:	The Phone lock alternative in the menu is hidden.
Selecting System ¹	The Select system alternative in the menu is hidden.
View Information ¹	The Information alternative in the menu is hidden.
Central Phonebook address	When an address to the central phonebook is specified, the alternative Central Phonebook will appear in the Phonebook menu and the short-cuts list. At delivery the address is set to 999999.

¹If all these alternatives are hidden the System alternative in the menu will be hidden.

Each profile in the menu can be hidden individually. This makes it possible to remove profiles that are not used from the menu. Note that it is still possible to change to the hidden profiles with help of Soft keys and Hot keys. See [15.5.8 Edit a Soft key](#) on page 47, and [15.5.9 Edit a Hot key](#) on page 48, for more information.

7.8 In Call Menu

The right soft key can be configured and used when a call is connected, as a short-cut to different functions. These settings are configured by the system administrator and cannot be set manually in the handset. Refer to *Configuration Manual, Ascom i75 VoWiFi Handset, TD 92431GB*.

8 Basic Operation

8.1 Switch the Handset On/Off

On: Press and hold  until the handset begins to start-up.



Off: Press and hold  until the *Shut down* view opens. Mark "Switch off" and press "Select". *Switch off* is displayed until the handset switches off.

8.2 Log a Shared Phone On/Off

The feature shared phone allows more than one user to use a handset. All parameters and settings that are set in the PDM are loaded to the handset upon logon. Parameters that are changed in the handset by a logged in user, are stored in the PDM. The message and call lists are deleted when a new user logs on to the handset.

The handsets are configured to be shared using the PDM. When a handset is configured to be a shared phone it can be used by any shared phone user in the system. The user profile must have the "personal phone" parameter disabled. If the user is configured as personal (i.e. not shared) the handset will become a personal phone upon first log on.

Log on to the handset:

- 1 Turn on the handset.
- 2 Enter the user name.
- 3 Enter the password, navigate using the   keys.
- 4 Press "Log on".

Log off the handset:

- 1 Long press on-hook.
- 2 Select log off or switch off.

If the handset does not find the WLAN upon start-up, a "No System" screen is shown. If the handset does not receive an IP address from the system a "No Access" screen is shown.

8.3 Turn Audible Signals On/Off

In stand-by mode a long press on the Mute button changes between audible signals on/off and the *Audio signal off* icon appears/disappears. The icon indicates a completely silenced handset. Only highest priority messages will override this silent mode.

8.4 Lock/Unlock the Keypad

Press *-key and then press "Lock" to lock the keypad. The *Locked keypad* icon indicates a locked keypad. Press *-key and then press "Unlock" to unlock the keypad.

The keypad can also be locked automatically, see [15.5.15 Turn On/Off Automatic Keypad Lock](#) on page 49 for more information.

Note: If a phone lock code has been set, the keypad will not be locked; instead the entire handset will be locked, requiring you to enter the lock code to unlock it. See [8.5 Lock/Unlock the Handset](#) on page 22.

8.5 Lock/Unlock the Handset

You can protect your IP handset from being used by others by locking it automatically when placed in a charger or switched off. The handset can only be unlocked with a 1 to 4 digit code. When the handset is locked, it is still possible to send all types of alarms.

The code is set in the handset's memory and can be changed from the handset, see [15.5.13 Change the Lock Code¹](#) on page 49. The handset can also be locked manually, see [15.5.12 Lock the Handset Manually](#) on page 49.

9 Calling

Note: The headset answering button is active during a call, or when the handset is ringing. It can also be used to get the line when pre-dialling. Pre-dialling is explained in section 9.3.1 below.

9.1 Open the Call List

The twenty last received/dialled telephone numbers are stored in a call list.

- 1 Press  to open the list. The list can be opened from the menu as well, which is described in [15.3 Call List](#) on page 43.

If the clock and date function is set, you will see the time for the call.

9.2 Incoming Call

The flashing LED, accompanied by a ring signal and/or a vibrating handset, give you notice of a call. Ring signal and vibrator can be disabled. The calling party's phone number and/or name is shown. The name will be shown if the calling party's phone number is stored in the local or central phonebook. Press  to answer the call. When a headset is connected to the handset, the answering button on the headset can be used to answer the call.

Other answering methods can also be set in the Profiles settings. The answering methods are *Ordinary*, *Auto*, *Loud*, and *Auto loud*. See [15.6 Profiles](#) on page 51 for more information.

When "Quick Answer" is enabled, an incoming call to a handset placed in the Desktop Charger will be answered automatically when the handset is lifted out of the charger. Quick Answer is enabled/disabled in the Settings menu; see [15.5.16 Enable/Disable Quick Answer](#) on page 50.

9.2.1 Turn Off Alert Signals at an Incoming Call



Press the Mute button before answering the call. All alert signals, including the vibrator, will become silent for that specific call.

9.2.2 End a Call

Press . When a headset is connected to the handset, the button on the headset can be used to end the call. All connected calls are ended. The total call time is shown in the display.

9.3 Outgoing Call

9.3.1 Pre-dial

Enter the number and press  to get the line. The number is shown on the display while dialling. If needed, you can press "Cancel" to return to the stand-by mode. By using   it is possible to step through a number and add/delete digits.

If a pause is required in the number, it is added by making a long press on the *-key. The pause is indicated with a "P" in the number.



9.3.2 Post-dial¹

Press  to get the line and enter the number.

9.3.3 Dial Using a Pre-programmed Hot key or Soft key



A Hot key or Soft key can be programmed with a telephone number. Press the pre-programmed Hot key or Soft key. The call will automatically be connected.

9.3.4 Dial a Number from the Call list

Enter the call list with , or from the menu. Select a number and press .

The number in the call list can be edited before the call is started. Press "Options", then select "Edit before call", press "Select", make the changes and press .



9.3.5 Dial a Number from a Message

You can dial a number included in a received message by pressing . The first number with three or more digits in the message is dialled. If the message is stored in the message list, open the list by pressing . Select the message and press .

9.3.6 Dial a Number from the Local Phonebook

Press the "Menu" Soft key and select "Contacts". Select "Local Phonebook". A name list is shown. Select the desired entry. Press  to make the call.

9.3.7 Dial a Number from the Central Phonebook

Press the "Menu" Soft key and mark the *Contacts* icon. Mark "Central Phonebook" and press "Search"; *Find:_* is shown. Enter the first characters in the name and press "Search". A list of matching names will be displayed. You can step to the next name in alphabetic order by pressing . Select desired name in the list and press  to make the call.

9.4 During a Call

9.4.1 Start a New Call during Conversation

Press "Options" during the call, and mark "New call". Dial the number and press . Switch between the connected calls by pressing "Options" and selecting "switch".

9.4.2 Transfer/Retrieve a Call

During the call, dial the number to the person you want to transfer the call to, and press .

In case the person you are trying to transfer the call to is not answering, you can take back the call by pressing  and then "Options". Mark "Retrieve:....." and press "Select".

9.4.3 "Blind" Transfer

Press "Options" during the call, mark "Transfer to new call" and press "Select". Dial the number to the person you want to transfer the call to. Press  to transfer the call. In this case the call cannot be retrieved.

1. Only applicable with the H.323 protocol

9.4.4 Put a Call on Hold/Retrieve the Call

Put a call on hold: press "Options" during the call, mark "Hold: (No.)" and press "Select". The call is put on hold and the text *On hold (No.)* is shown in the display.

To retrieve the call press "Options" once again and mark "Retrieve". The call is retrieved and the text disappears from the display.

9.4.5 Turn the Mute Mode On/Off

A press on the Mute button disconnects/connects the microphone. The text *Muted* is shown in the display when the microphone is off during a call.

9.4.6 Increase/Decrease the Speaker Volume

Press the upper part of the Volume button to increase the volume, and press the lower part of the Volume button to decrease the volume.

9.5 Loudspeaking Function

How to activate the loudspeaking function is dependent of the choice of answering method. An incoming call can be connected with loudspeaking function active by pressing the middle Soft key. During a call, a press on the middle Soft key activates the loudspeaking function. Press the middle Soft key again to turn it off.

You can also activate this function by selecting another answering method, see [15.6.4 Choose the Profile's Answering method](#) on page 52. For the loudspeaking function you have three choices in the menu:

- *Ordinary/Auto*. The loudspeaking function is turned on when the middle Soft key is pressed.
- *Loud*. A call is connected with the loudspeaking function turned on when  is pressed.
- *Auto loud*. An incoming call is automatically connected after 2 signals with the loudspeaking function turned on. If the call is answered before two signals have sounded, the loudspeaking function will not be turned on automatically.

10 Call Diversion¹

Either can a Soft key or Hot key be preprogrammed with a short-cut to the "Call diversion" function, or a profile be defined and used for the purpose. Refer to [15.5.8 Edit a Soft key](#) on page 47, [15.5.9 Edit a Hot key](#) on page 48, or [15.6.5 Set the Profile to Divert incoming Calls](#) on page 52.

All calls, calls when busy or calls at no answer can be diverted to other phone numbers.

10.1 Preset the Telephone Numbers

- 1 Press the preprogrammed Soft/Hot key and press "Set". *Divert to number:..* is displayed.
- 2 Enter the phone number you want to divert the calls to and press "Save".
- 3 Mark the next diversion alternative. Press "Set" and repeat point 2.

10.2 Divert Calls

From the default profile

- 1 Press the preprogrammed Soft/Hot key or select the predefined profile in the Profiles list.
- 2 Choose *All calls*, *On busy*, or *No answer* and press "Change". If the phone number has been preset the handset will return to stand-by mode, else continue with the next step.
- (3) *Divert to number:..* is displayed. Enter the phone number you want to divert the calls to and press "Save".

By changing to another preset profile

Changing to another profile is described in section 15.6.1.

¹.Only applicable with the H.323 protocol

11 Push-to-Talk Conference Call

Note: The Push-To-Talk function requires a Multi Point Control Unit (MCU), handsets programmed with PTT settings (from the PDM) and that groups have been created in the system.

The push-to-talk (PTT) function can be described as a group/conference call. A PTT session can be triggered from the system, by an alarm or by a user that sends an invitation to a PTT group from the handset.

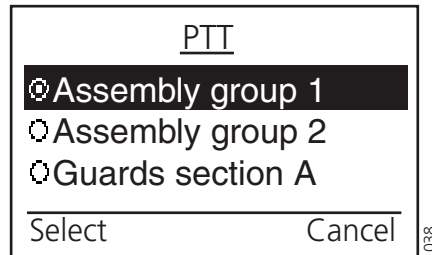

Figure 8. Example of groups in a PTT list

A PTT invitation can either be accepted or rejected by pressing a soft key. All group members that have accepted the PTT session, can listen to the conversation which by default starts in loudspeaking mode. If one of the group members wants to get in contact with the others, he simply presses and holds the Mute button to open the microphone. More than one handset can press the Mute button and start transmitting at the same time.

The function must be assigned to a Soft key, a Hot key or a Service. Refer to [15.5.8 Edit a Soft key](#) on page 47, [15.5.9 Edit a Hot key](#) on page 48, or [15.4.3 Edit a Service](#) on page 44.

11.1 Send an Invitation to a PTT Group

- 1 Press the preprogrammed Soft/Hot key or select the Service. The invitation is sent immediately to the preprogrammed PTT group.

11.2 Accept a PTT Conference Call

- 1 Press "Accept" to be connected to the PTT session. Default the handset will start in inverted mute and loud-speaking mode, but it can be configured differently in the received PTT message.
- 2 Press and hold the Mute button to open the microphone for transmitting. The microphone is muted again when the Mute button is released.

11.3 Reject a PTT Conference Call

- 1 Press "Decline" to reject the PTT session. The handset will return to the previously shown screen and the PTT message will be stored in the message list.

12 Messaging

12.1 Message List

The twenty last received messages are stored in a message list, if the total number of data characters does not exceed 20 000.

12.1.1 Display and Scroll between Messages

All received messages are saved in the message list. Open the message list by pressing \wedge , or from the menu, see page 41. Navigate in the list with \wedge \vee . The selected message is marked. Only one row per message is displayed.

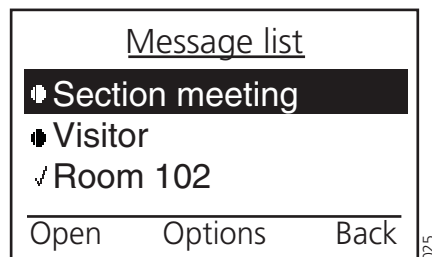

Figure 9. Unread and read ordinary messages

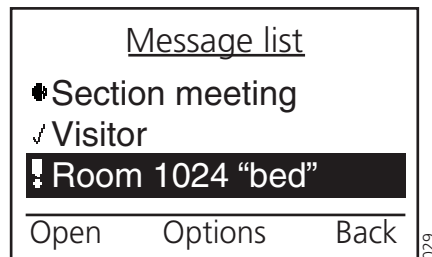

Figure 10. Message waiting for an answer

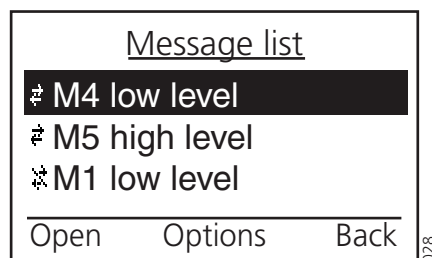







Figure 11. Unread and read interactive messages

Message indications:

-  The message is unread
-  The message is read
-  The message requires an action
-  The interactive message is unread
-  The interactive message is read

12.1.2 Read Stored Messages

- 1 Open the message as described in 12.1.1. Navigate in the list with \wedge \vee . The selected message is marked.
- 2 Press "Open" to see the whole message. The identity of the sending handset and time and date when the message was received, is shown.

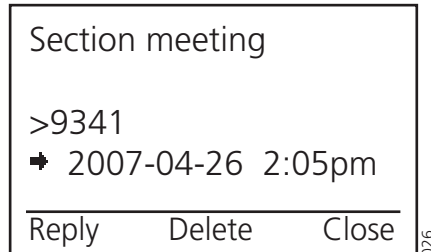

Figure 12. Opened message

A message that has been sent with a request for answer is indicated and viewed the same way as other messages, except for messages that have not been acknowledged.

Non-acknowledged message

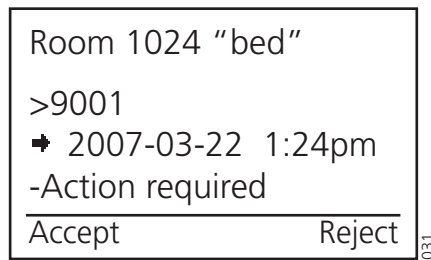

Figure 13. Opened non-acknowledged message

A non-acknowledged messages is indicated with an exclamation point in the list and when opened the text "Action required" is added to the message. Use the Soft keys to do a positive or negative acknowledgement.

Acknowledged message

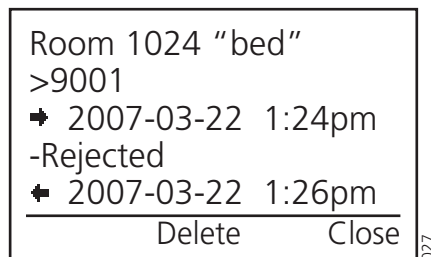

Figure 14. Opened acknowledged message

An acknowledged message is indicated by the text *Accepted* or *Rejected* and the time it was acknowledged.

Interactive message



Figure 15. Example of an interactive message

An interactive message has one ore more options. A very simple interactive message can look like the one in [figure 15](#). The options depends on the configuration in the client application, see [12.5 Interactive Messaging](#) on page 33.

12.1.3 Message Queuing and Message Priority

If several messages are received during a short period of time it is possible to specify at which rate the messages will be shown on the display. If a minimum time for messages to be displayed is set, each message will be shown without being interrupted by another message, except if the new message is of higher priority. Messages that are not shown yet are placed in a queue and the priority and time of reception determine the position in the queue. There are 9 levels of the priority. 1 is highest priority and 9 is lowest priority. If several of the messages have the same priority the message that was received first is shown first. If no minimum time is set (the parameter is set to 0) the priority order is disabled. Refer to the Configuration Manual i75 VoWiFi Handset. The total number of messages in the queue and the message list can not exceed the total number of characters stored, see [12.1 Message List](#) on page 28.

If a new message with a higher priority is received while another message is read the new message will replace the old message in the display. The old message will be placed in the

queue. If a new message with equal or lower priority is received while another message is read the new message will be placed in the queue.

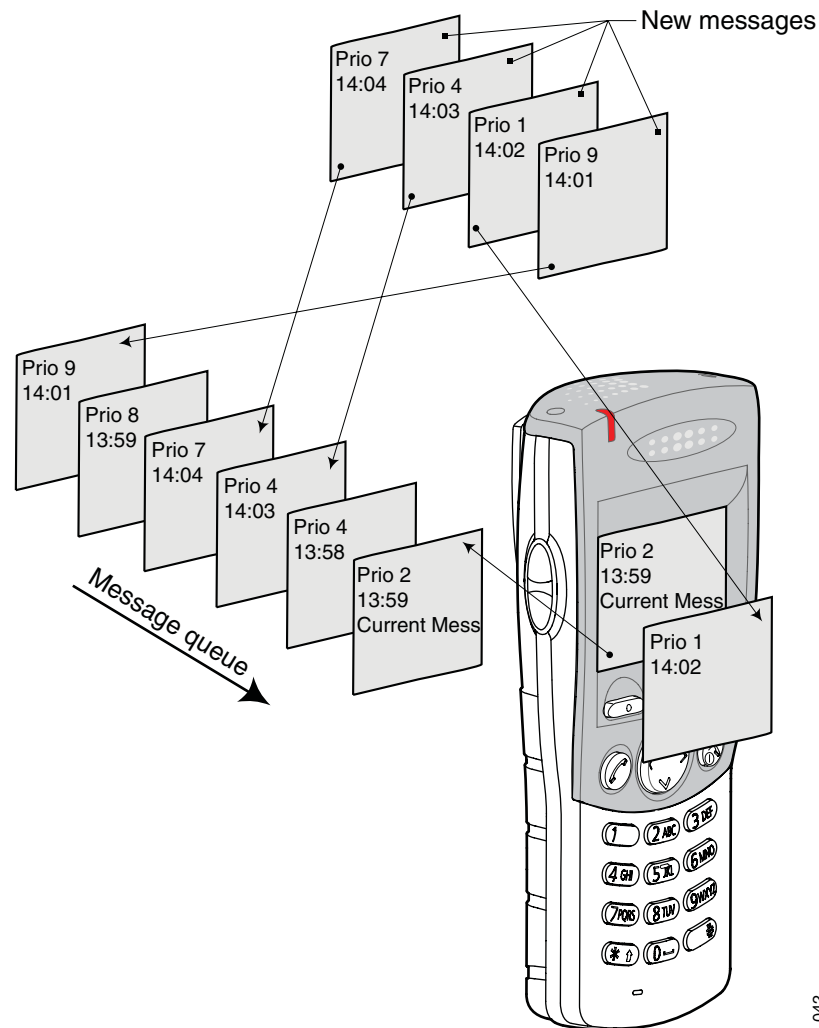

Figure 16. Figure of how the queue and priority works

Messages in the queue will be shown automatically when the minimum time has passed for the previous displayed message or the message is closed or deleted. Queued messages will always be shown instead of the idle-screen until the queue is empty.

Unread message indication while displaying a message

An envelope icon, see [3.3 Icons and Text in the Display](#) on page 11, will be flashing in the display if there are unread messages in the queue.

12.2 Basic Message Handling

12.2.1 Receive a Message

A flashing LED, accompanied by a message tone and/or a vibrating handset, gives you notice of a message. The message tone can be silenced by a press on the Mute button. If the handset is set in silent mode, the message tone will break through only if the message is urgent.

The message will be displayed for a preset period of time. If "Close" is pressed, or if a "Reply" is sent, the message will be marked as read.

The text size can be changed, see [15.5.11 Change Text Size in Messages](#) on page 49, and the message can also be displayed upside down, see [15.5.17 Display New Messages 180° Rotated \(upside down\)](#) on page 50.

12.2.2 Receive a Message during a Call

During a connected call a new message is indicated by a beep. The characteristics of the beep is the same as the message tone.

The new message is normally displayed without disconnecting the call, but parameter settings in the handset can determine that an urgent message is permitted to disconnect the call.

12.2.3 Receive a Message with Request for Answer

A message with request for answer is indicated and viewed the same way as other messages, see [12.2.1 Receive a Message](#). Use the Soft keys to do a positive or negative acknowledgement.

Accept/Reject the message

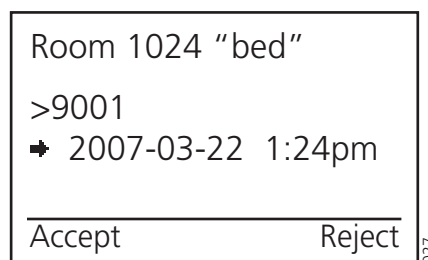

Figure 17. Message with request for answer

- 1 Press "Accept" or "Reject".

Note: The option "Delete" is not available for a message with request for answer; a message that has not been acknowledged can only be deleted from within the message list.

12.2.4 Delete a Message

Delete a received Message

Press the "Delete" when the message is displayed or marked in the Message list. The question *Delete message?* is shown; press "Yes".

Delete a Message stored in the Message list

Open the message list by pressing \wedge , or from the menu, see [15.2 Messages](#) on page 41. Navigate in the list with \wedge \vee . The selected message is marked. Press "Delete". The question *Delete message?* is shown; press "Yes".

12.3 Messaging between Handsets

Messaging between handsets is a system dependent function.

Messages from one handset to another is done from the menu entry "Messages". It is also possible to assign a Soft/Hot key or Service to the "Send message" function.

A Soft/Hot key or a Service can be programmed to send messages either to a predefined address or to any address in the system. If not predefined, the handset will ask for the destination address.

An incoming message is immediately displayed and the identity of the sending handset is shown on a separate row.

12.3.1 Send a Message to another Handset

Press the *Menu* Soft key, mark the *Messages* icon and press "Select". Mark "Send message" and press "Select". Enter the destination address or fetch it from the Local phonebook by pressing the Soft key with the *Contacts* icon; press "Select". If the address is not entered, an error message will be displayed. Enter text and press "Send". *Sending* will be displayed as a confirmation of the transfer.

12.4 Send a Message to a predefined Destination Address

Refer to [15.5.9 Edit a Hot key](#) on page 48, [15.5.8 Edit a Soft key](#) on page 47, or [15.4.2 Create a new Service](#) on page 44, how to predefine the destination addresses.

Press the Soft key, or press and hold the Hot key, or select the Service. Enter text and press "Send". *Sending* will be displayed as a confirmation of the transfer.

12.5 Interactive Messaging

Interactive Messaging (IM) is a function that extends basic messaging. It makes it possible for a user to access information from a client application in the system, from the handset.

An example can be a customized application that can be accessed from the handset. Data sent from the handset can be used to initiate the application to send the interactive message, see [12.7 Send Data from the Handset](#) on page 34. A list of actions can be included in the message sent from the application to the handset. The user can then select one action from the list. The action can be sending a message back to the application, and/or dialling a specific number etc.

An IM is indicated and viewed the same way as an ordinary message, see 12.2.1, but the *Interactive message* icon is added in front of the message. It is saved along with other messages in the message list.

Interactive Messaging is a system dependent function.

12.5.1 Interactive Messages with Function Keys

If there are function keys specified in an Interactive Message, they will be mapped to the Soft keys and the alphanumeric keys. Function Key ID (A) will be mapped to the left Soft key, Function Key ID (B) will be mapped to the middle Soft key, and Function Key ID (C) will be mapped to the right Soft key. Function key IDs (0)–(9) will be mapped to the corresponding alphanumeric keys.

12.5.2 Interactive Messages without Function Keys

Open an Interactive Message (IM) the same way as an ordinary message. If the IM gives you several options, mark the one you want and press "Select". If the selected option requests input, enter the information needed and press "Select".

A long press on the "#- key" will change to digit input mode to facilitate entering numbers.

12.5.3 Multilayer Interactive Messaging

Interactive messages can have multiple layers. A multilayer message have different options defined for the soft keys. When a soft key is pressed and an option is selected new options are defined for the soft keys depending on the previous selection.

It is the soft key options that are changed, the text message is unchanged.

12.6 Voice Mail

12.6.1 Receive a Voice Mail

A ring signal and the *New voice mail* icon in the display indicate that a new voice mail has arrived. You can listen to voice mail by selecting the "Voice mail" entry in the "Messages" menu.

12.7 Send Data from the Handset

12.7.1 Data Send

It is possible to send user entered data from the handset by pressing a pre-programmed Hot key or Soft key, or selecting a Service. "Data send" can be used for opening a door, starting/stopping a machine etc. The data can either be predefined, or entered after the Hot key/Soft key is pressed or Service is selected.

The data can be predefined when programming the Soft/Hot key or Service, see [15.5.8 Edit a Soft key](#) on page 47 or [15.4.3 Edit a Service](#) on page 44.

12.7.2 Send Data with a Prefix

Data with a prefix is sent from the handset by pressing a pre-programmed Hot key or Soft key or selecting a Service. Data with prefix can be used to send information to an application in the system. The prefix is predefined by the user when programming the Hot/Soft key or Service, see [15.5.8 Edit a Soft key](#) on page 47 or [15.4.3 Edit a Service](#) on page 44. The data is entered after the Hot key/Soft key is pressed or Service is selected.

13 Presence Management

Note: The presence option is only available when the handset has logged into and received an activity list from a Presence Management system, and received time and date from an NTP server.

The activity list and the names of the activities depends on the configuration in the Presence Management system.

The function "Presence" is added to Settings when the above criteria are fulfilled, but it can also be assigned to a Soft key/Hot key or a Service. Refer to [15.5.8 Edit a Soft key](#) on page 47, [15.5.9 Edit a Hot key](#) on page 48, or [15.4.3 Edit a Service](#) on page 44.

13.1 Select Presence Activity

- 1 Press the "Menu" Soft key, mark the *Settings* icon and select "Presence", or press the preprogrammed Soft/Hot key or select the Service.
- 2 Mark the cause for not being present in the *Presence* list by using the Navigation key and press "Select".

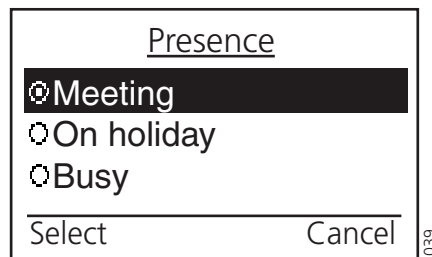

Figure 18. Example of an activity list

- (3) Enter the time or the date the selected activity will end.

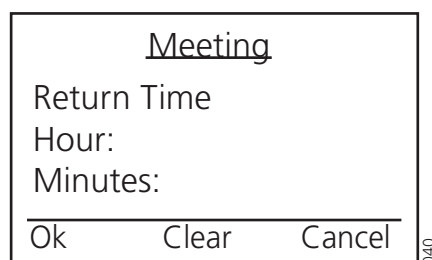

Figure 19. Settings when the activity will end the same day

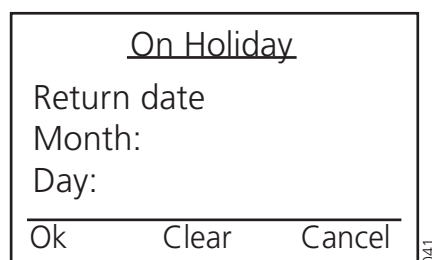

Figure 20. Settings when the activity will end another day

- 4 Press "Ok"

14 Alarm Operation

14.1 Acoustic Localisation Signal

A parameter in the handset determines whether or not an Acoustic Localisation Signal (ALS) should sound after an alarm. The ALS is silenced by pressing the *Mute* button.

14.2 Push-button Alarm

Press the red alarm button twice within two seconds to activate the alarm. An information text, by default *Personal Alarm*¹, is displayed. The alarm is sent to the alarm central that distributes it further. After that the handset returns to stand-by mode. Note that you can always trigger the alarm when you are speaking, editing your settings, or while the phone is locked.

14.3 Test Alarm

Press and hold the red alarm button until the information text is displayed, default *Test Alarm*¹.

14.4 No-movement Alarm

Note: The No-movement alarm requires that the licence option is made available in the handset. For information on how to add a licence, refer to *Configuration Manual, Ascom i75 VoWiFi Handset TD 92431GB*.

You can activate/deactivate the alarm function in the menu, see [15.5.6 Deactivate/Activate No-movement alarm](#) on page 46, or by programming a Soft/Hot key as a short-cut to the function, see [15.5.8 Edit a Soft key](#) on page 47. The Soft/Hot key changes the state of the alarm, i.e. if it is deactivated it will be activated and vice versa. Press the Soft key, or press and hold the Hot key, to put the alarm in or out of operation, respectively.

The *No-movement alarm on* icon on your display is an indication that the No-movement alarm is in operation.

Send No-movement alarm

The No-movement alarm will go off when you have not moved within a preset period of time (default 30 seconds). Before the alarm is activated a warning signal sounds and the *No-movement on* icon starts to flash. If you do not cancel the alarm by pressing a key, the alarm is sent and *No-movement alarm*¹ is shown in the display.

Activate No-movement alarm after sending

When a No-movement alarm has been sent, it is made active again by pressing a key or by moving the handset.

1. The information text can be changed using a parameter in the handset

14.5 Man-down Alarm

Note: The No-movement alarm requires that the licence option is made available in the handset. For information on how to add a licence, refer to *Configuration Manual, Ascom i75 VoWiFi Handset TD 92431GB*.

You can activate/deactivate the alarm function in the menu, see [15.5.7 Deactivate/Activate Man-down alarm¹](#) on page 46, or by programming a Soft/Hot key as a short-cut to the function, see [15.5.8 Edit a Soft key](#) on page 47. The Soft/Hot key changes the state of the alarm, i.e. if it is deactivated it will be activated and vice versa. Press the Soft key, or press and hold the Hot key, to put the alarm in or out of operation, respectively.

The *Man-down alarm on* icon on your display is an indication that the Man-down alarm is in operation.

Send Man-down alarm

The Man-down alarm will go off when the handset is tilted more than 45° for a preset period of time (default 30 seconds), for example if you fall. Before the alarm is activated a warning signal sounds and the *Man-down alarm on* icon starts to flash. If you do not cancel the alarm by pressing a key, it is sent and *Man-down alarm¹* is shown in the display.

Activate Man-down alarm after sending

When the man-down alarm has been sent, it is made active again by moving the handset to upright position or pressing a key.

14.5.1 Delay Time for No-movement and Man-down Alarms Warning Signal

By setting a parameter, the time before the warning for no-movement and man-down alarms can be delayed for ten minutes, i.e. no-movement and man-down will not be detected during the time period. When the warning signal sounds, press the Mute button to delay the time to next warning for up to ten minutes.

14.6 Alarm with Data

Additional data for example a location code, can be sent along with an alarm. The data must manually be defined and stored by the user via the menu. This is a system dependent function.

14.7 Automatic Call after an Alarm

The handset can be programmed to call a predefined telephone number directly after an alarm. Each alarm type in the handset must be programmed with the specific telephone number. It can be any external or internal telephone number but also a pre-defined group of handsets.

This is a system dependent function that also require a parameter setting in the IP handset.

Note: An ongoing call will be disconnected, unless it is an alarm call, and an incoming call will be rejected when the alarm is transmitted. Then the telephone number associated with the alarm will be dialled.

1.The information text can be changed using a parameter in the handset

14.8 Automatic Alarm after Emergency Call

A parameter can be set to automatically send an alarm after you have called the emergency number.

15 Menu Operation

Changes made from the menu are by default saved, but a handset parameter determines if changes are to be saved or not. If this parameter is set to not save, then all changes will be discarded when the handset is restarted.

15.1 Contacts

- 1 Enter the menu by pressing the "Menu" Soft key, or the Navigation key < or >; the *Contacts* icon is marked.
- 2 Press "Select". The alternatives in Contacts are *Local phonebook* and *Central phonebook*.

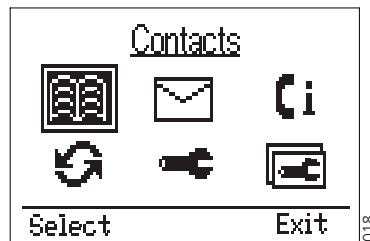

Figure 21. The Contacts icon is marked.

15.1.1 Find an Entry in the Local Phonebook

- 1 Mark the *Contacts* icon and press "Select"; *Local phonebook* is marked.
- 2 Press "Search"; *Find:* will appear.
- 3 Enter the first letter in the name or the whole name. Press "Search". The first name corresponding to your search will appear.
- 4 Use ^ v to scroll through the entries. Note that the entries sorting order might change depending on the selected handset language.

Note: The search function is not accessible if the Local phonebook is empty.



15.1.2 View an Entry in the Local Phonebook

- 1 Mark the *Contacts* icon and press "Select".
- 2 Mark "Local phonebook" and press "Select". The first entry is marked.
- 3 Use ^ v to scroll through the list.
- 4 Press "Details" to view the entry; the name and number will appear.
- 5 Use ^ v to view the next entry in the list. Press "Back" to step back. Note that the entries sorting order might change depending on the selected handset language.

15.1.3 Add an Entry to the Local Phonebook

- 1 Mark the *Contacts* icon and press "Select".
- 2 Mark "Local phonebook" and press "Select".
- 3 Press "Add"; *Name: _* and *Number: _* will appear. The handset is in text input mode and the name can now be added.

Note: If one or more contacts already have been added, you will have to press "Options" first, then mark "Add" and press "Select".

- 4 Enter the name.
Change between upper and lower case characters by pressing the *- key on the keypad. Change between character and digit input mode by pressing and holding the #-key. You can delete the character/digit to the left of the cursor by pressing "Clear". Press and hold "Clear" to delete several characters one at a time.
- 5 Press  and enter the number.
A pause can be added to the number by making a long press on the *-key. The pause is indicated with a "P" in the number.
By using  and  it is possible to step back and forth in a name/number and add/delete a character/digit in the middle of it.
- 6 Press "Save"; *Entry saved* is shown. The handset will automatically return to the local phonebook.



15.1.4 Delete an Entry in the Local Phonebook

- 1 Mark the *Contacts* icon and press "Select".
- 2 Mark the "Local phonebook" and press "Select". The first entry is marked.
- 3 Scroll through the list and mark the name you want to delete. Press "Options"; *Add* is marked.
- 4 Scroll through the list and mark "Delete:". Press "Select"; the question *Delete entry?* will appear. Press "Yes" ("No" will take you back to the local phonebook); *Entry deleted* is shown. The handset will automatically return to the local phonebook.

Delete when Viewing or after Searching the Entry

- 1 View or search for an entry by using the instructions in [15.1.2 View an Entry in the Local Phonebook](#) on page 39 or [15.1.1 Find an Entry in the Local Phonebook](#) on page 39.
- 2 Press "Options" and mark "Delete:".
- 3 Press "Select"; the question *Delete entry?* will appear. Press "Yes" ("No" will take you back to the local phonebook); *Entry deleted* is shown. The handset will automatically return to the local phonebook.

15.1.5 Edit an Entry in the Local Phonebook

- 1 Find or view the entry using the instructions in [15.1.2 View an Entry in the Local Phonebook](#) or [15.1.1 Find an Entry in the Local Phonebook](#).
- 2 Press "Options"; *Add* is marked.
- 3 Scroll through the list and mark "Edit:". Press "Select"
- 4 First edit the name. Change between upper and lower case characters by pressing the *-key on the keypad. Change between character and digit input mode by pressing and holding the #-key. The middle Soft key is used as a Clear (C) button.
- 5 Press  to edit the number. It is possible to step through a name/number using   and add/delete a character/digit in the middle of it.
- 6 Press "Ok"; *Entry saved* is shown. The handset will automatically return to the local phonebook and the saved entry is marked.

15.1.6 Find an Entry in the Central Phonebook

- 1 Mark the *Contacts* icon and press "Select".
- 2 Mark "Central phonebook". Press "Search"; *Find:_* will appear.
- 3 Enter a name or number.
- 4 Press "Search". For more information about how to search in the Central phone book, see *Installation and Operation Manual Phonebook Service, TD 92360GB*.

The search result is presented. The handset will remember the search result until it is overwritten by a new search result or manually cleared from the handset. This means that the next time the Central phonebook is selected, the latest search result is opened.

15.1.7 Delete the Central Phonebook Search Result

- 1 Mark the *Contacts* icon and press "Select". The search result is presented.
- 2 Press "Options".
- 3 Mark "Clear result" and press "Select"
- 4 Press "Yes". *Search result cleared* is shown.

15.1.8 Add an Entry from the Search Result to the Local Phonebook

- 1 Mark the *Contacts* icon and press "Select".
- 2 Mark "Central phonebook" and press "Select".
- 3 Search for the entry. If no search result exists, see [15.1.6 Find an Entry in the Central Phonebook](#).
- 4 Mark desired entry.
- 5 Either press "Options", mark "Add to phonebook: .." and press "Select", or press "Details" and "".
- 6 Press "Save". *Entry saved* is shown.

15.1.9 Send a Message to an Entry in Contacts

- 1 Select Local phonebook or Central phonebook, see [15.1.1 Find an Entry in the Local Phonebook](#) or [15.1.6 Find an Entry in the Central Phonebook](#).
- 2 Mark desired entry and press "Options".
- 3 Mark "Send msg" and press "Select".
- 4 Enter message text and press "Send". *Sending..* is shown.

15.2 Messages

- 1 Enter the menu by pressing the *Menu* Soft key, or the Navigation key < or >.

- 2 Select the *Messages* icon and press the Soft key "Select" to enter the Messages submenu.

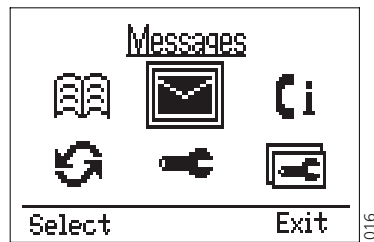

Figure 22. The Messages icon is marked.

15.2.1 Message List

- 1 Mark the "Message list" and press "Select".

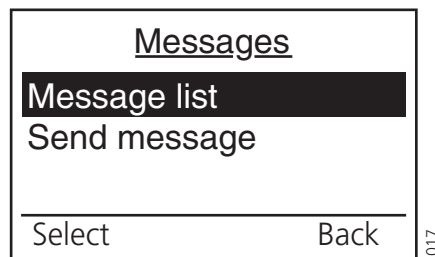

Figure 23. Messages is selected and the Message list in the submenu is marked.

All received messages in the Message list are shown. The messages are either marked as read or unread.

- 2 Mark the desired message.
- 3 Press "Open" to view the whole message. The date and time it was received is shown.
- 4 Press "Close" to return to the message list.

Send a reply on the message

- 1 Open the desired message, see [15.2.1 Message List](#) on page 42, and press "Reply".
- 2 Enter text and press "Send".

Delete the message

- 1 Open the desired message, see [15.2.1 Message List](#) on page 42, and press "Delete"; the question *Delete message?* will appear.
- 2 Press "Yes". The handset will automatically return to the message list.

Delete all Messages

- 1 Mark the desired message in the list, see [15.2.1 Message List](#) on page 42, and press "Options".
- 2 Mark "Delete all" and press "Select"; the question *Delete all messages?* will appear.

- 3 Press "Yes" ("No" will take you back to the Message list); *All messages deleted* is shown and after one second you will automatically be back in stand-by mode.

15.3 Call List

- 1 Enter the menu by pressing the "Menu" Soft key, or the Navigation key < or >.
- 2 Mark the *Call list* icon and press "select" (this is the same call list that is reached by pressing ✓ in stand-by mode).

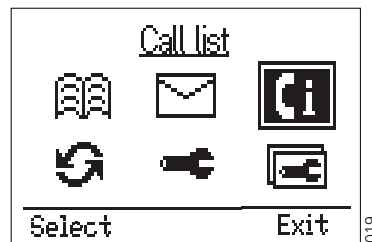

Figure 24. The Call list icon is marked.

- 3 In the call list, toggle between name and number by pressing < or >.

15.3.1 Save a Number from the Call List to the Local Phonebook

- 1 Mark the *Call list* icon and press "Select". The first number in the list is marked.
- 2 Press the Soft key with the " + " icon. The number is added and you only have to enter the name. Change between upper case and lower case characters by pressing the *-key on the keypad. Change between character and digit input mode by pressing and holding the #-key. The middle Soft key is used as a Clear button.
- 3 Press "Save"; "Entry saved" is shown. The handset will automatically return to the Call list.

15.3.2 Delete a Number in the Call List

- 1 Mark the *Call list* icon and press "Select" (this is the same Call list that is reached by pressing ✓ in stand-by mode). The first number in the list is marked.
- 2 Mark the number you want to delete. Press "Options"; *Edit before call* is marked. Scroll down to "Delete"; Press "Select". The handset will automatically return to the Call list.

15.3.3 Delete All Numbers in the Call List

- 1 Mark the *Call list* icon and press "Select" to enter Call list (this is the same Call list that is reached by pressing ✓ in stand-by mode). The first number in the list is marked.
- 2 Press "Options"; *Edit before call* is marked. Mark "Delete all". Press "Select"; the question *Delete all numbers?* is shown.
- 3 Press "Yes" ("No" will take you back one step); "All numbers deleted" is shown. The handset will automatically return to stand-by mode.

15.4 Services

- 1 Enter the menu by pressing the *Menu* Soft key, or the Navigation key < or >.

- 2 Mark the *Services* icon. Press "Select"; a list with all created *Services* is shown.

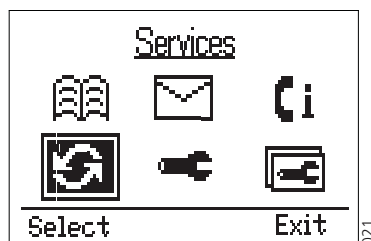

Figure 25. The *Services* icon is marked.

15.4.1 Activate a Service

- 1 Mark the *Services* icon and press "Select".
- 2 Mark the *Service* you want to activate. Press "Select"; the service will be activated.
 - If predefined data is sent, the text *Sending...* is shown. The handset will automatically return to the list and the selected service is marked.
 - If data with prefix is to be sent; enter the data and press "Send". The text *Sending...* is shown and the handset will automatically return to menu mode.
 - If a phone call is to be made the phone number will be dialled.
 - If a message is to be sent; enter the message address (may be predefined), press "Ok", enter message text and press "Send". The text *Sending...* is shown and the handset will automatically return to menu mode.

15.4.2 Create a new Service

- 1 Mark the *Services* icon and press "Select".
- 2 Press "Add"; *Name:_* will appear. The handset is in text input mode and the name can now be added.

Note: If services already have been created, you will have to press "Options" first, then select "Add service" and press "Select".

- 3 Enter a name that describes the service you want to add, for example, if you want this service to open a door, then name it *Open door*.
- 4 Press "Save"; the new name is marked and added to the list.
- 5 Select "Function:Not used".
- 6 Press "Select" to enter functions. The functions available are; *Data send*, *Data with prefix*, *Phone call*, and *Send message*.
- 7 Choose the function you want the service to have and press "Select".
- 8 Dependant on the function you have chosen, enter data, prefix, phone number, or message address (if you want a predefined address), and press "Select" to save the setting. The handset will automatically return to the service and the function is marked.

15.4.3 Edit a Service

- 1 Mark the *Services* icon and press "Select". A list with all *Services* is shown.
- 2 Mark the one you want to edit. Press "Options" and select "Change:".
- 3 Press "Select".
- 4 Mark "Name:" and press "Edit". Change the name and press "Save".

- 5 Mark Function:" and press "Select".
- 6 Choose a function and press "Select". Enter data, prefix, phone number, or text message address and text; press "Save". The handset will automatically return to the Service and the function is marked.

15.4.4 Delete a Service

- 1 Mark the *Services* icon and press "Select". A list with all Services is shown.
- 2 Mark the one you want to delete. Press "Options".
- 3 Mark "Delete:"; the question "Delete service?" is shown. Press "Yes"; "Service deleted" is shown for 1 second. The handset will automatically return to the list and the next Service is marked.

15.5 Settings

- 1 Enter the menu by pressing the "Menu" Soft key, or the Navigation key < or >.
- 2 Mark the *Settings* icon and press "Select".

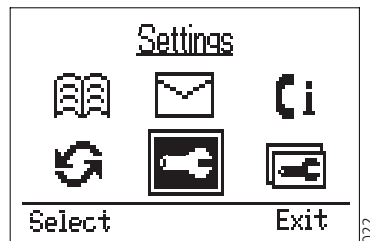

Figure 26. The Settings icon is marked.

The alternatives in Settings are; *Alert signals*, *Audio volumes*, *Alarm settings*, *Soft key*, *Hot key*, *General*, and *System*.

- In *Alert signals* you can change your settings for all audible signals and the vibrator.
- In *Audio volumes* you can change your settings for the speaker volume, the loudspeaker volume and the headset volume.
- In *Alarm settings* you can turn No-movement and Man-down alarm on and off.
- In *Soft key* and *Hot key* you can assign the Soft/Hot key a function.
- In *General* you can change the following settings: Language, Text size, Phone lock, Time & date, Auto key lock, Quick answer, New message rotated, and Owner ID.
- In *System* you can select system and get information about the handset.

15.5.1 Change the Ring Volume

- 1 Mark the *Settings* icon and press "Select".
- 2 Mark "Alert signals" and press "Select".
- 3 Mark "Ring volume:" and press "Select". Mark the desired volume level by using the Navigation key < or >. You have six available alternatives; Level 1 to 5, or Silent.

If you want to hear the volume level during the changing, press "Play". Press "Stop" to stop the sound.
- 4 Activate your choice by pressing "Select"; the selected volume is shown. The handset will automatically return to the Alert signals list and the volume is marked.

15.5.2 Change the Ring Signal

- 1 Mark the *Settings* icon and press "Select".
- 2 Mark "Alert signals" and press "Select".
- 3 Mark "Ring signals" and press "Select". You can change the ring signal for *Internal call*, *External call*, or *Callback*.
- 4 Mark the desired ring signal; press "Change".
- 5 Choose the desired signal. Available alternatives are *Beep*, *Low*, *Medium*, *High*, and *Mixed*.
If you want to hear the new signal, press "Play". Press "Stop" to stop the sound.
- 6 Activate your choice by pressing "Select"; the selected Ring signal is shown. The handset will automatically return to the Ring signals list and the changed Ring signal is marked.

15.5.3 Change the Speaker, Loudspeaker or Headset Volume

- 1 Mark the *Settings* icon and press "Select".
- 2 Mark "Audio volumes" and press "Select".
- 3 Mark "Speaker volume", "Loudspeaker volume", or "Headset volume" and press "Select".
- 1 Mark the desired volume level by using the Navigation key < or >. You have ten available alternatives; Level 1 to 10.
- 2 Activate your choice by pressing "Select"; the selected volume is shown.

15.5.4 Vibrator On/Off

- 1 Mark the *Settings* icon and press "Select".
- 2 Mark "Alert signals" and press "Select".
- 3 Mark "Vibrator" and press "Change"; the *Vibrator* checkbox is selected/cleared.

15.5.5 Key Beep On/Off

- 1 Mark the *Settings* icon and press "Select".
- 2 Mark "Alert signals" and press "Select".
- 3 Mark "Key beep" and press "Change"; the *Key beep* checkbox is selected/cleared.

15.5.6 Deactivate/Activate No-movement alarm¹

- 1 Mark the *Settings* icon and press "Select".
- 2 Mark "Alarm setting" and press "Select".
- 3 Mark "No-movement" and press "Change"; the *No-movement* checkbox is selected/cleared.

15.5.7 Deactivate/Activate Man-down alarm¹

- 1 Mark the *Settings* icon and press "Select".

1.Requires an Alarm License and an i75 Handset equipped with the alarm option. For information on how to add a licence, and how to activate the alarms in the PDM, refer to *Configuration Manual, Ascom i75 VoWiFi Handset TD 92431GB*.

- 2 Mark "Alarm setting" and press "Select".
- 3 Mark "Man-down" and press "Change"; the Man-down checkbox is selected/cleared.

15.5.8 Edit a Soft key

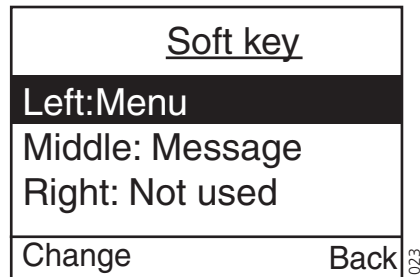

- 1 Mark the *Settings* icon and press "Select".
- 2 Mark "Soft key" and press "Select".
- 3 Mark the Soft key you want to edit and press "Change". *Name:* is marked.
- 4 Press "Edit".
- 5 Enter a name of maximum seven characters. Press "Ok". *Changes saved* is shown and the handset automatically returns to the soft key.
- 6 Mark "Function:".
- 7 Press "Change" to enter functions.

- 8 Choose the desired function for the Soft key. See table below.

Soft key/Hot key functions:

Data send:	Press "Select". Enter data if you want it to be predefined, or leave it out if you want to enter data after pressing the Soft key, press "Save".
Data with prefix:	Press "Select". Enter prefix and press "Save".
Phone call:	Press "Select". Enter phone number and press "Save". Alternatively, press the Phonebook Soft key and choose a contact from the Local phonebook and then press "Save". Tone sender on will be indicated with a "T" in the number, and off with "-". A pause can be added by making a long press on the *-key. The pause is indicated with a "P" in the number.
Short-cut:	Press "Select". Assign the short-cut; <i>Local phonebook, Central phonebook, Message list, Absent, No-movement, Man-down, Edit alarm data, Menu, Call list, Services, RSSI, Network statistics, Call diversions^a or Presence</i> . Press "Select".
Send message:	Press "Select". When <i>Message address</i> is shown you can leave it blank, or you can predefine a destination address; press "Select".
Change profile:	Press "Select". Mark the desired profile and press "Select".
Presence ^b	Press "Select".
PTT ^c	If needed a specific PTT group can be assigned. Press "Select".
Not used:	Press "Select". <i>Not used</i> will be indicated in the Soft key list.

a. Only applicable with the H.323 protocol

b.Requires that the handset has logged into a Presence management System.

c.Requires a Multi Point Control Unit (MCU) and that groups have been created in the system.

The name of the selected function is shown. The handset will automatically return to the soft key.

15.5.9 Edit a Hot key

- 1 Mark the *Settings* icon and press "Select".
- 2 Mark "Hot key" and press "Select".
- 3 Mark the one you want to edit (0, 1, 2,.....9) and press "Change".
- 4 *Name:* is marked; press "Edit".
- 5 Enter a name of maximum sixteen characters. Press "Ok". *Changes saved* is shown and the handset automatically returns to the hot key.
- 6 Mark "Function". Press "Change" to enter functions.
- 7 Choose the function you want the Hot key to have. The functions for a Hot key are the same as for a Soft key, see table under [15.5.8 Edit a Soft key](#) on page 47.

Note: This function can be disabled by your system administrator.

15.5.10 Select Language

- 1 Mark the *Settings* icon and press "Select".
- 2 Mark "General" and press "Select".
- 3 Mark "Language" and press "Select".

Note: There is a "*" symbol in front of *Language*, making it easy to find if you have changed language by mistake.

- 4 Mark the desired language. Press "Select". The language is shown. The handset will automatically return to the list of general settings.

15.5.11 Change Text Size in Messages

- 1 Mark the *Settings* icon and press "Select".
- 2 Mark "General" and press "Select".
- 3 Mark "Text size" and press "Select".
- 4 Choose between Small and Medium. Press "Select". The chosen text size is shown and the handset automatically returns to the list of general settings.

15.5.12 Lock the Handset Manually¹

- 1 Mark the *Settings* icon and press "Select".
- 2 Mark "General" and press "Select".
- 3 Mark "Phone lock". Press "Select" and mark "Lock phone". Press "Select"; the handset is locked.

15.5.13 Change the Lock Code¹

- 1 Mark the *Settings* icon and press "Select".
- 2 Mark "General" and press "Select".
- 3 Mark "Phone lock" and Press "Select".
- 4 Mark "Set lock code" and Press "Select".
- 5 Enter the new lock code and press "Ok".

15.5.14 Time and Date Settings

Set Time and Date Format

- 1 Mark the *Settings* icon and press "Select".
- 2 Mark "General" and press "Select".
- 3 Mark "Time & date" and Press "Select".
- 4 Mark "Time format" and press "Select".
- 5 Mark the desired time format (12 hour or 24 hour) and press "Select". The handset will automatically return to the list.
- 6 Mark "Date format" and press "Select".
- 7 Mark the desired date format and press "Select".

15.5.15 Turn On/Off Automatic Keypad Lock

- 1 Mark the *Settings* icon and press "Select".
- 2 Mark "General" and press "Select".

1.The i75 Handset cannot be locked with an "empty" lock code.

- 3 Mark "Auto key lock" and press "Change". The *Auto key lock* checkbox is selected/cleared. In stand-by mode a locked keypad is indicated by the *Locked keypad* icon.

15.5.16 Enable/Disable Quick Answer

- 1 Mark the *Settings* icon and press "Select".
- 2 Mark "General" and press "Select".
- 3 Mark "Quick answer" and press "Change". The *Quick answer* check box is selected/cleared.

15.5.17 Display New Messages 180° Rotated (upside down)

- 1 Mark the *Settings* icon and press "Select".
- 2 Mark "General" and press "Select".
- 3 Mark "New message rotated" and press "Change". The *New message rotated* checkbox is selected/cleared.

Note: When this parameter is set, the call information for incoming calls is also displayed upside down.

15.5.18 Set Owner ID

- 1 Mark the *Settings* icon and press "Select".
- 2 Mark "General" and press "Select".
- 3 Mark "Owner ID" and press "Edit".
- 4 Enter a name. Change between upper and lower case by pressing the *-key on the keypad. Press "Save". The new ID is shown. The handset will automatically return to the list of general settings.

15.5.19 Change Display Contrast

- 1 Mark the *Settings* icon and press "Select".
- 2 Mark "General" and press "Select".
- 3 Mark "Display contrast" and press "Select". Mark the desired contrast level by using the Navigation key < or >. You have fifteen available alternatives; level 1 to 15.
- 4 Activate your choice by pressing "Select"; the selected contrast level is shown. The handset will automatically return to stand-by mode.

15.5.20 Select System

- 1 Mark the *Settings* icon and press "Select".
- 2 Mark "System" and press "Select".
- 3 Mark "Select system" and press "Select".
- 4 Mark the desired system and press "Select". *System selected* is shown. The handset will automatically return to the system menu.

Select System Set as a Hot key

If you are often moving between systems, it might be convenient to change system quickly, therefore you can set this function as a Soft key or Hot key.

To change systems: just press the pre-programmed Soft/Hot key to connect to the next available VoWiFi system (A, B, C or D).

15.5.21 System Information

It is possible to obtain general information about the handset by doing the following:

- 1 Mark the *Settings* icon in the menu. Press "Select".
- 2 Mark "System" and press "Select".
- 3 Mark "Information". Press "Select" to view information about:
 - ESSID: The ID of the system to which the handset is connected.
 - IP: The IP address of the handset assigned by the system.
 - MAC: The MAC (hardware) address of the handset. This is stored in the handset and will always be the same.
 - SW version: Here you can see which version of the handset software you have.
 - Alarm license: If the handset is equipped with a license or not.

Tip: There is a quick access code you can use to enter the information mode directly without using the menu. The quick access code is *#46#.

15.6 Profiles

- 1 Enter the menu by pressing the *Menu* Soft key, or the Navigation key < or >.
- 2 Mark the *Profiles* icon and press "Select".

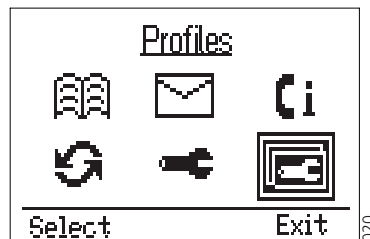

Figure 27. The Profiles icon is marked

The handset is equipped with ten Profiles. Two profiles are preset at delivery (*Normal* and *In charger*) and the remaining eight profiles are left for the user to define.

Normal Profile

The *Normal* profile is the default profile.

In charger Profile

The *In Charger* profile is activated when the handset is placed in the charger and deactivated when removed. Your last selected profile is automatically chosen when the handset is removed from the charger.

User defined Profiles

Eight profiles can be defined and saved by the user. The profiles can, for example, be used to create a special headset profile with different ring signal volume and automatic answer of incoming calls. Another example is when several users are sharing the same handset. Each user can then define his own settings, for example; *type of ring signal*, *volume*, *answering method*, *Soft key settings* etc. Note that one has to change to the user defined profiles manually.

15.6.1 Change between the Profiles

- 1 Mark the *Profiles* icon and press "Select". A list with all profiles is shown.
- 2 Mark the Profile you want to change to and press "Select"; the name of the marked Profile is shown. The handset will automatically return to the list.

A Soft/Hot key can be programmed to change profiles, see [15.5.8 Edit a Soft key](#) on page 47 for more information.



15.6.2 Change Profile Settings

- 1 Mark the *Profiles* icon and press "Select". A list with all profiles is shown.
- 2 Mark the Profile in which you want to change the settings and press "Options".
- 3 Mark "Edit:" and press "Select". The handling is then according to the ordinary settings, see [15.5 Settings](#) on page 45, but you also have the possibility to set *Absent On/Off*, choose answering method, give the profile a new name and to divert incoming calls.

15.6.3 Set the Profile to Absent On/Off

Follow the instructions described in [15.6.2 Change Profile Settings](#), and view the profile's settings. Mark "Absent" and press "Change"; the *Absent* checkbox is selected/cleared.

15.6.4 Choose the Profile's Answering method

- 1 Follow the instructions described in [15.6.2 Change Profile Settings](#), and view the profile's settings. Mark "Answer:" and press "Select".
- 2 Choose the answering method you want. Select between; *Ordinary*, *Auto*, *Loud*, or *Auto loud*.
 - Ordinary; press  or the middle Soft key for loudspeaking function.
 - Auto; the call is automatically connected.
 - Loud; press  and the call is connected with loudspeaking function turned on.
 - Auto loud; the call is automatically connected with loudspeaking function turned on.
- 3 When you have chosen type of answering method, press "Select"; the name of the selected method is shown. The handset will automatically return to the list and the new answering method is marked.

15.6.5 Set the Profile to Divert incoming Calls¹

- 1 Mark the *Profiles* icon and press "Select". A list with all profiles is shown.
- 2 Mark the Profile in which you want to change the settings and press "Options".
- 3 Mark "Edit:" and press "Select".

¹.Only applicable with the H.323 protocol

- 4 Mark "Call diversions" and press "Select".
- 5 You can choose; *All calls*, *On busy*, or *No answer*. Press "Change". *Divert to number:..* is displayed.
- 6 Enter the telephone number you want to divert to and press "Save".

15.6.6 Preset Phone Numbers for the Diversions alternatives¹

- 1 Mark the *Profiles* icon and press "Select". A list with all profiles is shown.
- 2 Mark the Profile you wish to have as diversion profile and press "Options".
- 3 Mark "Edit:" and press "Select".
- 4 Mark "Call diversions" and press "Select". The diversions alternatives are displayed.
- 5 Mark the first alternative, "All calls", and press "Set". *Divert to number:..* is displayed.
- 6 Enter the telephone number you want to divert your calls to, and press "Save". The handset returns to the diversions alternatives.
- 7 Mark the next diversion alternative. Press "Set" and repeat point 6.

15.6.7 Customizing the Profiles Menu

A profile can be prevented from being shown in the list. This is an easy way to hide profiles that are not used. A setting in the flash memory determines whether the profile should be in the list or not.

1.Only applicable with the H.323 protocol

16 System Handling

16.1 Register a New VoWiFi System

You can register up to four different VoWiFi systems on your handset.

When you have registered more than one system, you can manually select which system to connect to, see [15.5.20 Select System](#) on page 50.

16.2 Field Upgrade

Software and parameters in the i75 VoWiFi Handset can be upgraded by using the Portable Device Manager (PDM). The PDM exists in two versions, *Windows* version and *System* version.

Refer to the *Configuration Manual, Ascom i75 VoWiFi Handset TD 92431GB* for more information.

17 Status text in Display

17.1 Accessibility and Voice Quality

The base network is not always available. If you do not get in contact with your system, contact your system administrator.

For various reasons, some functionality in the system may be inaccessible, causing various status texts to appear.

No System

When you leave the system's coverage area the text "No System" will appear in the display. Additionally, a parameter can be set to enable a short beep to sound when the message is shown.

Note: When re-entering the coverage area it can take a couple of minutes before the handset automatically has registered into the system.

It is also possible to get an out of coverage warning signal by setting a flash memory parameter.

No Access

If the handset has found the system but for some reason cannot connect to it, the text "No Access" is shown.

Voice Only

If the handset is unable to connect to the IMS, messaging will not be available and the text "Voice Only" will be shown.

Messaging Only

If the handset is unable to connect to the gateway, voice calling will not be available and the text "Messaging Only" will be shown.

17.2 Error Codes

When the base network is available a call may sometimes still fail. In such cases, the error code shown indicates the reason for the failed call.

No response

The called portable is unavailable "not registered". The error code can also appear the first two minutes a called handset is out of coverage or if the battery is removed without turning the handset off.

No Channel Available

The connection fails because no appropriate channel is available to take the call. For example when a handset is designed for two simultaneous calls and a user tries to make a third call. Another cause can be that the handset has lost contact with the VoIP Gateway.

Call Failed

Unable to contact the called handset.

User Busy

The person being called is already engaged in another call, or has declined your call.

Invalid Number

The called number does not exist in the system, or the connection between the VoIP Gateway and the PBX is lost.

17.3 Environmental Requirements

i75 VoWiFi Handset

- Only use the handset in temperatures between 0 °C to +40 °C.
- Avoid exposing in direct sunlight or close to other heat sources.
- Protect your handset from aggressive liquids and vapours.
- Keep the handset away from strong electromagnetic fields.

Battery

- Do not immerse the battery into water or throw into fire.
- Use the desktop charger or the wall mounted charging rack for charging. Charge the battery for at least one hour the first time you use the battery. Note that the wall mounted charger with a battery pack adapter has to be used if the battery alone is to be charged.

18 Maintenance

18.1 Charge the Battery

The battery requires charging when the handset is not in use or when the *Battery* icon in the display shows a low charge.

Place the handset in the charger. A beep indicates connection with the charger. The charging status is shown by the battery icon in the handset display. After approximately 2–6 hours the handset is fully charged, indicated by a filled battery icon. If the handset is switched off when placed in the charger, the charging indicator will be shown. The charging indicator will show a full battery if the battery is fully charged.

18.1.1 Charging Spare Batteries

Spare batteries can be charged in the wall-mounted Charging Rack equipped with the Battery Pack Charger.

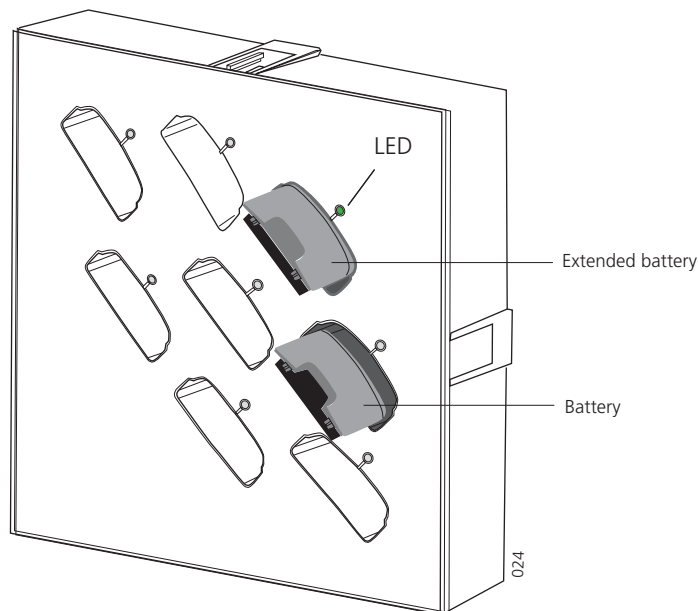

Figure 28. Inserting a battery in the battery charger.

Place the battery in the charging slot. The LED on the adapter shows an orange light. When the battery is fully charged, the LED will show a green light.

If an error occurs during charging, the LED will show a red light.

If the LED does not start to flash when the battery is placed in the charging slot, the battery is not in contact. Remove the battery and put it into the charging slot again.

Note: It is not possible to charge spare batteries in the Desktop Charger.

18.2 Remove the Battery

The battery is fastened by two hooks. To remove the battery, press firmly on the two release buttons on the sides of the handset.

18.3 Change the Clip

A hinge-type belt clip is mounted on the i75 VoWiFi Handset at delivery. The clip can be replaced with a covering plate also included in the delivery, or a swivel-type belt clip that can be ordered separately.

Tools required:

- Pozidriv Point size 1

19 Related Documents

Data Sheet, Ascom i75 VoWiFi Handset	TD 92318GB
Quick Reference Guide Ascom i75 VoWiFi Handset	M0274030
Configuration Manual, Ascom i75 VoWiFi Handset	TD 92431GB
Installation and Operation Manual Phonebook Service	TD 92360GB
Installation and Operation Manual, Portable Device Manager (PDM), Windows version	TD 92325GB
Installation and Operation Manual, Portable Device Manager (PDM), System version	TD 92378GB

Document History

For details in the latest version, see change bars in the document.

Version	Date	Description
A		First Released version
B	2006-09-22	Updated for iteration R2, including SIP.
C	2007-09-25	<ul style="list-style-type: none">• The appendices; <i>Programming the Handset</i>, <i>Upgrade the Firmware</i>, and <i>Add a New i75 VoWiFi Handset to the Site</i>, have been removed and added to the <i>Configuration Manual</i>, <i>Ascom i75 VoWiFi Handset TD 92431GB</i>.• Following chapters have been added:<ul style="list-style-type: none">– 7.8 In Call Menu on page 20– 10 Call Diversion on page 26– 11 Push-to-Talk Conference Call on page 27– 12.1.3 Message Queuing and Message Priority on page 30– 13 Presence Management on page 35– 15.6.5 Set the Profile to Divert incoming Calls on page 52– 15.6.6 Preset Phone Numbers for the Diversions alternatives on page 53– 15.5.19 Change Display Contrast on page 50• Illustrations added to 12.1 Message List on page 28• Services and Settings menu tree have been updated (see chapters 7.4 and 7.5).

Index

A

Antenna 7

B

Battery 8, 56

Battery care 6

Battery disposal 6

Belt clip

hinge-type 2

swivel-type 2

C

Call Failed 56

Case

covering plate 58

materials 7

Chemical resistance 3

Clip

covering plate 8

swivel-type 8

D

Display 8

E

ESSID 1, 51

Exposure to radio frequency signals 4

F

FCC compliance statements 5

Frequency range 3

H

Headset

with hearing protection 2

with mic 2

I

i75 Medic Protector 1

i75 Protector 1

IC requirements for Canada 6

Icon

123 12

ABC 12

abc 12

Action required 13, 28

Add contact 13

Audio signals 11

Battery 11

Call list 13

Contacts 13

Get contact from phonebook 13

Headset 12

Incoming call 12

Interactive message 12, 28

Key lock 12

Loudspeaking off 11

Loudspeaking on 11

Man-down alarm on 12

Message continue 12

Messages 13

Missed call 12

New message 13

New voice mail 12

No-movement 12

Off-hook 11

Outgoing call 12

Padlock 12

Profiles 13

Read interactive message 13, 28

Read message 12, 28

Services 13

Settings 13

Signal strength 11

Unread message 12, 28

Invalid Number 56

IP 51

K

Keypad 8

M

MAC address 51

message list 13

Messaging Only 55

N

No Access 55

No Channel Available 55

No response 55

No System 55

O

Operation procedures

FCC 4

Owner ID 11

P

Pause in a phone number 10, 23, 40, 48

PDM 1

Potentially explosive atmospheres 4

Precautions 3

R

RF Exposure 5

S

SAR 4

Software version 51

Stand-by mode 11

Status information 11

U

User Busy 56

V

Voice Only 55

VoIP 1

VoWiFi 1

W

Warranty notification 6

WiFi 1

Write letters 10